

Introduction

A4/2

TeSys U - Power bases, control modules, connectors

Type of product

Range

Page

Standard power base,
basic control functionalities
Direct and reversing

Up to 18.5 kW



A4/10

TeSys U - Communication components

Parallel type cabling system
Principle and components

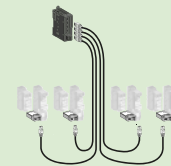

A4/16

Bus type cabling systems
Principle, panorama and components

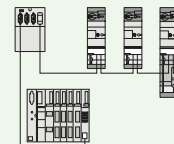

A4/21

LUFPE communication gateway



A4/30

TeSys U - Accessories

Short circuit current limiter



A4/31

Handles and accessories
for rotary control

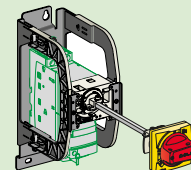

A4/32

Handles and accessories
for integration into a MCC drawer

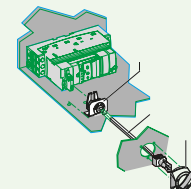

A4/33

TeSys U with Altistart U01 Soft starters
and Variable speed controllers



A4/34

Technical Data for Designers

A4/41

From traditional solution to ...

Motor circuit breaker:
TeSys GV2L



Magnetic protection
 > short-circuit protection

Contactor:
TeSys D



Control
 > Start /Stop
 Status monitoring
 > signaling
 > alarm monitoring

Protection relay:
TeSys LRD



Thermal protection
 > overload

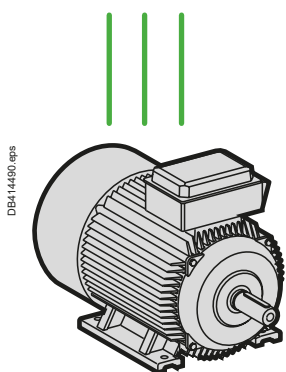

TeSys U

...TeSys U starter-controller



TeSys U starter-controller

> All basic or advanced protection and control functions in one block and more...

- > Overload indication and alarm
- > Status report, remote control via communication bus

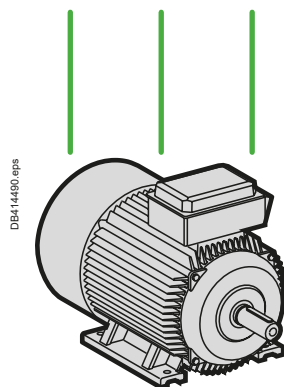

✓ **TeSys U**
can be used in
80 %
of motor protection
and control
applications.



1 All in one

- Optimising space in enclosures.
- Total coordination (No contact welding on short circuit).
- Reduces installation times.

2 Simplicity of choice

- Controlled power.
- Protection functions ensured.
- Signaling functions, communication with PLC ensured.

3 Universal mounting

- On DIN rail or grid.

4 Conventional projet design

- Conventional control scheme with start , stop push buttons.

5 Electrically simple

Basic scheme of a TeSys U starter-controller

- Protection and power control functions acting on a single set of contact (QF1).
- The control unit (CU) monitors the voltage and current. In case of fault, it releases the coil, causing tripping.
- The coil is controlled by manual orders from an operator. Automatic control from a PLC is achieved with other diagrams.

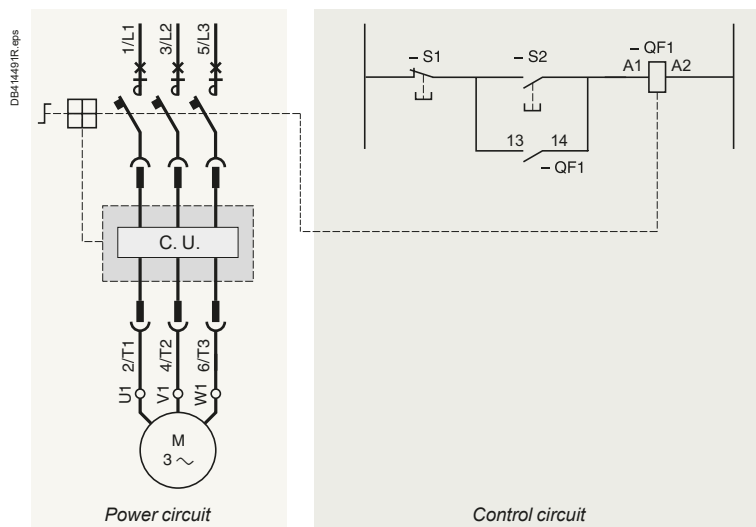

TeSys

TeSys U All-in-one motor starters

Introduction

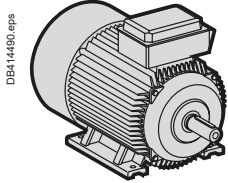

Motor up to

- 7.5 kW / 1-phase 230 V / 50-60 Hz.
- 18.5 kW / 3-phase 400-440 V / 50-60 Hz.
- 18.5 kW / 3-phase 500 V / 50-60 Hz.
- 22 kW / 3-phase 690 V / 50-60 Hz.
- Non-reversing or reversing.

Common characteristics

Short-circuit protection

- I_{sc}:
 - 50 kA at ≤ 400 V
 - 10 kA at 500 V
 - 4 kA at 690 V.
- Up to 690 V AC.

Overload protection

- From 0.15 to 38 A, 6 setting ranges (tripping 14.2 x I setting).
- Test button.
- Adjustment lock.
- Coil choice: 24 V, 48...72 V, 110...240 V DC/AC.

3 power contacts

- For non-reversing (reversing with reverser block).
- I_{max}, for 12 A power base (direct - reversing):
 - 12 A at up to 500 V / 50 Hz
 - 9 A > 500 V, up to 690 V.
- I_{max}, for 38 A power base (direct - reversing):
 - 38 A at up to 500 V / 50 Hz
 - 21 A > 500 V, up to 690 V.

1 NO contact

1 NC contact

- 5 A / max. 690 V AC or 250 V CC.

Other monitoring contacts

- 5 A / max. 690 V AC or 250 V DC.

Communication modules

- Modbus,
- Ethernet,
- CANopen,
- DeviceNet,
- Advantys stb,
- Profibus DP,
- AS-interface.

Dimensions

- Base:

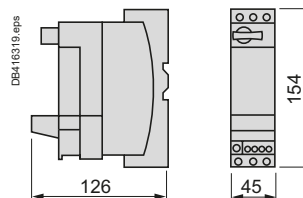

- Base + reverser block:

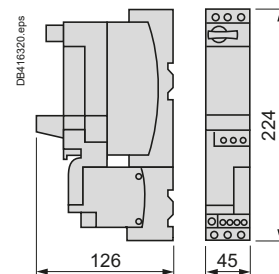

TeSys

TeSys U All-in-one motor starters

Introduction

DB41483 eps

TeSys U

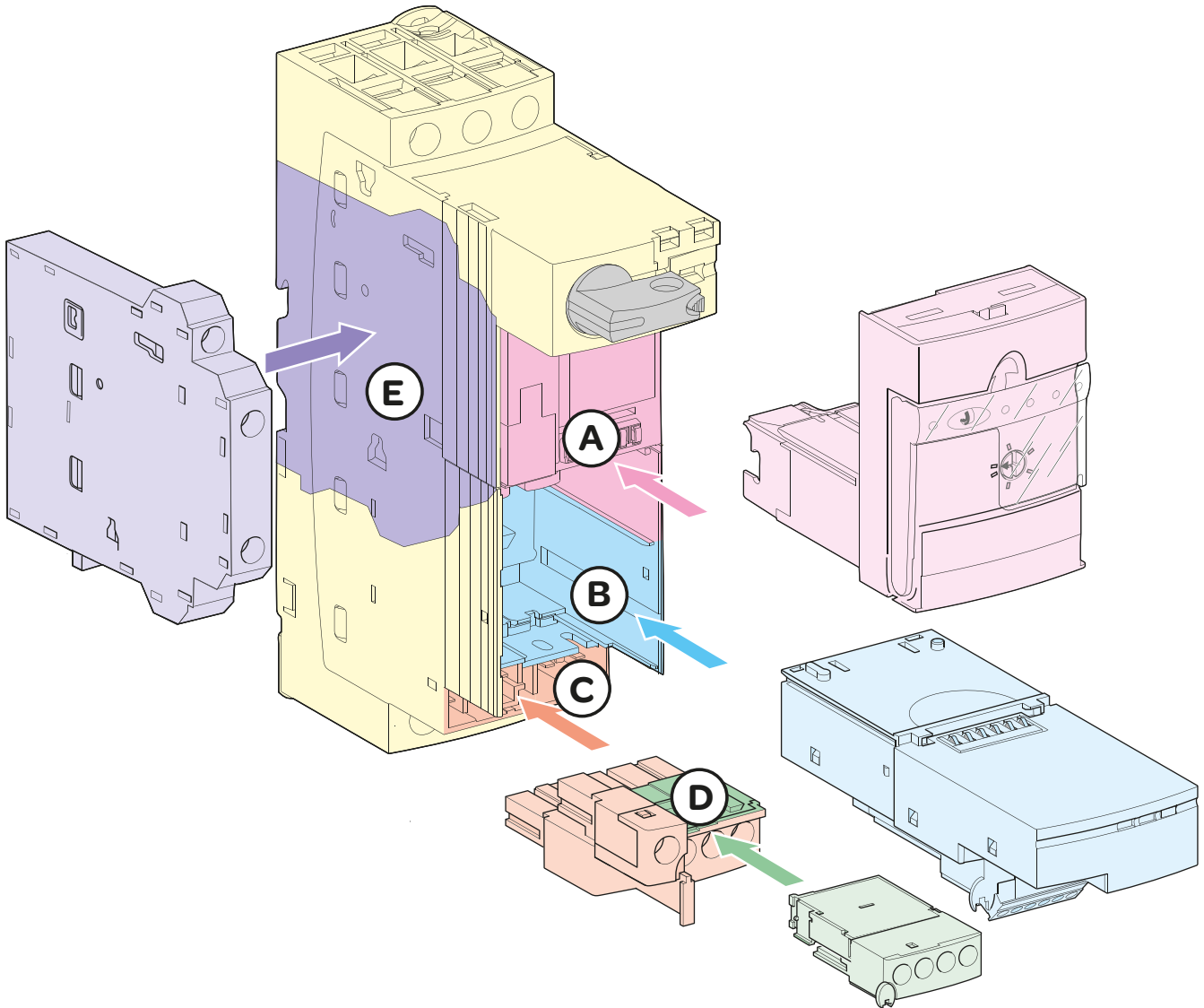

The modularity principle

- Power base
- A Cavity for control unit
- B Cavity for auxiliary module
- C Cavity for control terminal block
- D Cavity for additional contact block or shutter
- E Space for additional block fastening

Power Base

This is the basic constituent of the motor starter, it is composed of the power contacts, the control coil, the opening / closing mechanism of the protection device and the control pad.

Additional lateral block

Composed of the protection device signaling contacts.

Control unit

Composed of the power base management processor and setting knobs.

Auxiliary module

Depending on its type, it integrates load status contacts or a communication processor or an alarm processor.

Control terminal block

It is composed of two terminals "coil control", 1 NO auxiliary contact, 1 NC auxiliary contact. It can be eventually connected to an auxiliary communication module via a dedicated cable.

Additional block

It includes protection device additional signaling contacts. By default, this is a simple shutter.

TeSys

TeSys U All-in-one motor starters

Introduction

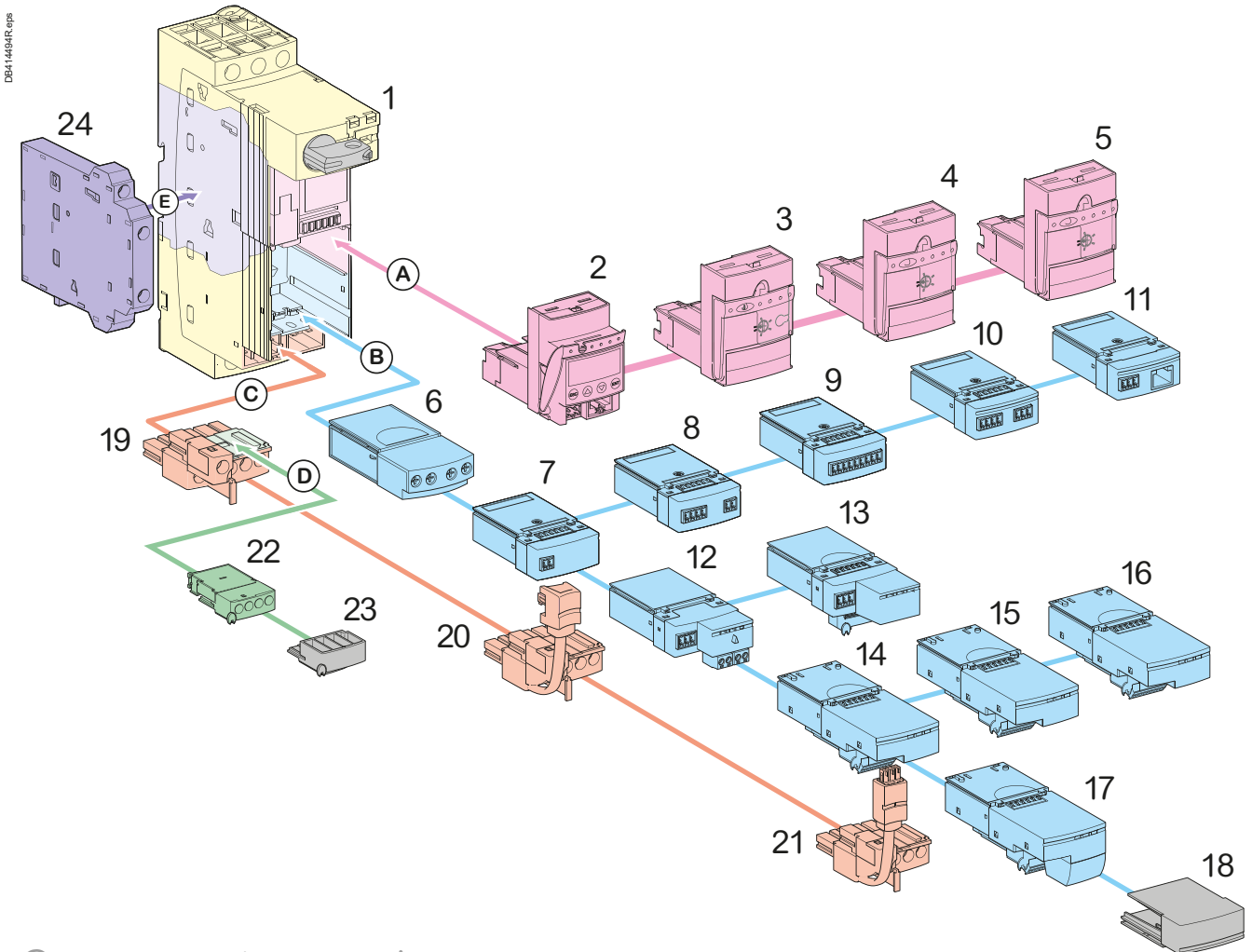

TeSys U

Components overview

Power base

- 1- LUB
Non reversing power base - 1 rotation direction

Control units

- 2- LUCM
Multifunctional control unit
- 3- LUCB/LUCC/LUCD
Advanced control units
- 4- LUCA
Standard control unit
- 5- LUCL
Magnetic protection control unit

Auxiliary module

- 6- LUFN
Auxiliary contacts module

Load monitoring auxiliary modules

- 7- LUFW10
Overload alarm module
- 8- LUFDH11
Overload alarm module with manual reset
- 9- LUFDA01/LUFAD10
Overload alarm module with automatic reset/remote reset
- 10- LUFV2
Motor load indication module

Communication auxiliary modules

- 11- L UFC00
Telefast parallel liaison module, with RJ45 connector
- 12- ASILUFC5/ASILUFC51
AS-Interface c. m.
- 13- LULC033
Modbus c. m.
- 14- LULC07 Profibus DP c. m.
- 15- LULC08 CANopen c. m.
- 16- LULC09 DeviceNET c. m.
- 17- LULC15 Advantys STB c. m.

Shutters

- 18- LU9C1
Shutter for module cavity
- 23- Shutter for contacts additional block cavity

Control terminal blocks

- 19- LU9BN11
Terminal block for imbedded auxiliary contacts
- 20- LU9BN11C
Coil terminal block with its connecting cable
- 21- LU9BN11L
Coil terminal block with its connecting cable

Additional contacts blocks

- 22- LUA1
Additional contacts
- 24- LUA8
side-mounting additional contacts

TeSys

TeSys U All-in-one motor starters

Introduction

DB1445R.eps

TeSys U

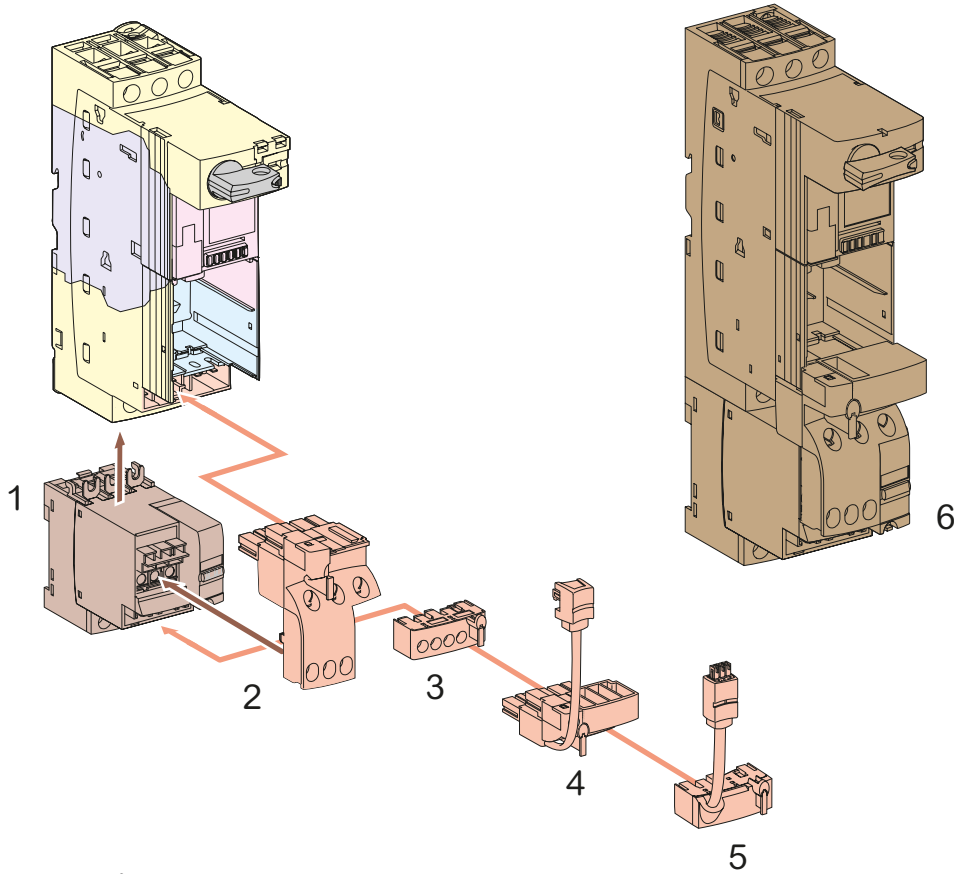

Additional components overview

Reverser block

- 1- LU2MB0●●
vertical-mounting reverser block

Evolving reversing power base

- 6- Pre-assembled reversing power base LU2B12

Control terminal blocks

- 2- LU9MR1C
Base/block assembling connector, with terminal block for imbedded auxiliary contacts
- 3- LU9M1
Coil terminal block for wired control
- 4- LU9MRC
Coil terminal block with its connecting cable for communicating control (only compatible with a selection of com. modules).
- 5- LU9MRL
Coil terminal block with its connecting cable for communicating control (only compatible with a selection of com. modules).

TeSys

TeSys U All-in-one motor starters

Introduction

DB414497 eps

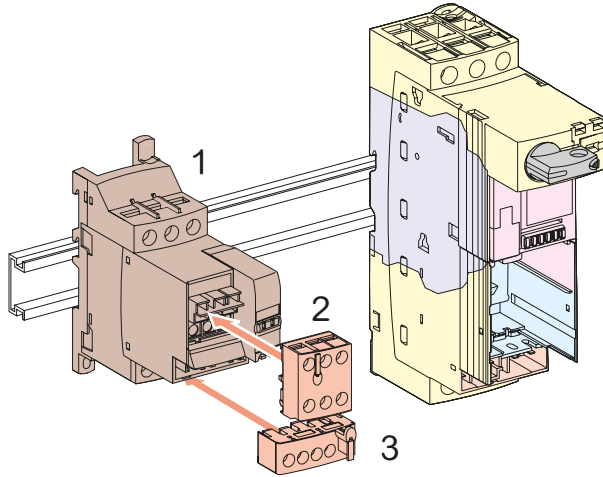

TeSys U

Additional components overview

Reverser block

- 1- LU6MB0●●
Side-mounting reverser block

Terminal blocks for electrical remote control

- 2- LU9MR1
Terminal block for 2 direction control (pulse or maintained control)
- 3- LU9M1
Terminal block for power base coil interlocking.
With direction of rotation monitoring contacts

TeSys

TeSys U All-in-one motor starters - Power bases

Product references



1 direction:
LUB12, LUB32, LUB38



1 direction:
LUB120, LUB320, LUB380



2 direction:
LU2B12●●, LU2B32●●,
LU2B38●●



LU9MR1C



LU2MB0●●



LU9M1



LU6MB0●●



LU9MR1

Power bases

TeSys U starters are composed with separate elements: power component + control units + auxiliary components.

The power base includes the electro mechanical parts. It is selected according to:

- Motor power to be handled
- Number of direction of rotation to be controlled: 1 or 2
- Type of control to be achieved: Basic or Advanced.

Basic control

- 1- direction rotation control
- 2 - direction rotation control
- Overload + Short circuit protection
- Main power monitoring
- Status signaling contacts

Advanced control

- Functions of basic control
- + Digital display of electrical values
- + Overload alarms
- + Network/bus communication

Function	Max motor standard power (400 V) kW	Lip_in (400 V) A	References	
			Basic ctrl	Advanced ctrl
1-direction rotation	5.5	12	LUB12	LUB120
	15	32	LUB32	LUB320
	18.5	38	LUB38	LUB380
2-direction rotation	5.5	12	LU2B12●● ⁽¹⁾	LUB120 + reverser block ass.
	15	32	LU2B32●● ⁽¹⁾	LUB320 + reverser block ass.
	18.5	38	LU2B38●● ⁽¹⁾⁽²⁾	LUB380 + reverser block ass.

⁽¹⁾ Replace the 2 dots by the coil voltage code below – AC is 50-60 Hz.

⁽²⁾ With BL or FU code only.

Coil voltage (V)	24~	24~	48...72 ~ or ~	110...220 ~ and 110...240~
Code	BL	B	ES	FU

Reverser blocks - assemblies

A reverser block assembly has to be added to the power base (LUB120 to 380) to build an 'Advanced control' with '2-direction of rotation' TeSys U starter.

Reverser blocks with 2 mounting possibilities:

- vertical mounting – mounted aspect: refer to LU2B12, 32, 38
- side mounting, on a Din rail.

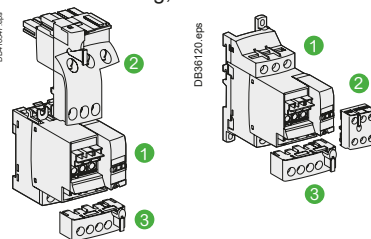

Vertical mounting Side mounting

Blocks	References	
	Vertical mounting	Side mounting
1 Reverser block	LU2MB0●● ⁽¹⁾	LU6MB0●● ⁽¹⁾
2 Aux. contacts connector	LU9MR1C	LU9MR1
3 Coil supply connector	LU9M1	LU9M1

⁽¹⁾ Replace the 2 dots by the coil voltage code below – AC is 50-60 Hz.

Coil voltage (V)	24~	24~	48...72 ~ or ~	110...220 ~ and 110...240~
Code	BL	B	ES	FU

Main technical characteristics

Power bases

1-direction power base overall dimensions (HxWxD) : 154 x 45 x 126 mm

2-direction power base (assembly with vertical mounting reverser block) overall dimensions (HxWxD): 224 x 45 x 126 mm

Power bases are delivered with protective blanking plates.

3 power poles, for connections of a 1-phase or 3-phase motor

Screw clamp power terminals, for up to 2 x 6 mm² conductors

Screw clamp control terminals, for up to 2 x 1.5 mm² conductors

LUB12,32,38 imbedded terminals:

- coil supply,
- NO (13-14) contact (for control push button)
- NC (21-22) contact (for control push button).

Additional signaling contact modules provide more possibilities.

Reversing assemblies

LU2MB0, LU6MB0:

3 power poles, for connections of a 1-phase or 3-phase motor, screw clamp power terminals, for up to 2 x 6 mm² conductors
LU9 connectors: screw clamp control terminals, for up to 2 x 1.5 mm² conductors

LU2MB0●●, LU6MB0●● provide terminals for power circuits.

LU9MR1C, LU9MR1 provide signalling contact terminals (82-81-84) that indicate the direction of rotation.

LU9M1 provides coil supply terminals (A2-A1-A3) and 2 NO contact terminals (A1-B1, A3-B3) for direction control.

TeSys

TeSys U All-in-one motor starters - Control units

Product references



LUCA, LUCB, LUCC, LUCD, LUCL series

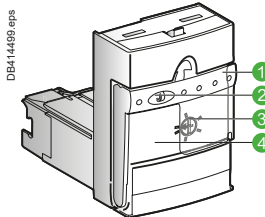

LUCA.....

- 1 Extraction and locking handle.
- 2 Sealing of locking handle.
- 3 Ir adjustment dial.
- 4 Locking of settings by sealing the transparent cover.

TeSys U starters are composed with separate elements: power component + control units + auxiliary modules. The control unit includes electronic components and the current adjustment dial. The control unit is selected according to:

- Motor power to be handled.
- Type of protection: thermal+magnetic or magnetic only.

Control units for power bases with basic control

LUCA - thermal + magnetic (standard) units

- Protection against overload: 14.2 x Ir (setting current).
- Protection against short circuit: 13 x Ir max (max setting current).
- Protection against missing or unbalanced phases.
- Protection against insulation fault (protection of equipment only).
- Class 10 tripping.
- Frequency 50...60 Hz.

LUCL - magnetic units

- Protection against short circuits.
- To be used when a standard power base is connected to a motor drive or a soft starter, as they provide the overload protection.

Note: both LUCA and LUCL units can be used in the advanced power bases LUB120 and LUB320.

Maximum standardized power ratings of 3 phases motors 50/60 Hz			Setting range	Lip_in mounting on the power base - Rating	Control unit product reference ⁽¹⁾	
400/440 V	500 V	690 V			Thermal + magnetic	Magnetic
kW	kW	kW	A	A	LUCA	LUCL
0.09	-	-	0.15...0,6	12 and 32	LUCAX6●●	LUCLX6●●
0.25	-	-	0.35...1,4	12 and 32	LUCA1X●●	LUCL1X●●
1.5	2.2	3	1.25...5	12 and 32	LUCA05●●	LUCL05●●
5.5	5.5	9	3...12	12 and 32	LUCA12●●	LUCL12●●
7.5	9	15	4.5...18	32	LUCA18●●	LUCL18●●
15	15	18.5	8...32	32	LUCA32●●	LUCL32●●
18.5	18.5	22	9.5...38	38	LUCA38●● ⁽²⁾	LUCL38●● ⁽²⁾

⁽¹⁾ Replace the 2 dots by the coil voltage code below – AC is 50-60 Hz.

⁽²⁾ With BL or FU code only.

Coil voltage (V)	24~	24~	48...72 ~ or ~	110...220 ~ and 110...240~
Code	BL	B	ES	FU



TeSys

TeSys U All-in-one motor starters - Control units

Product references

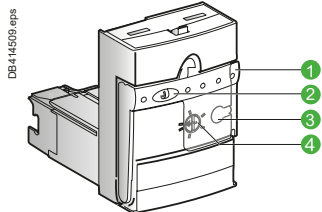

LUCB●●●●, LUCC●●●●, LUCD●●●● control units

- 1 Extraction and locking.
- 2 Handle sealing of locking.
- 3 Handle
- 4 Ir adjustment dial test push button.

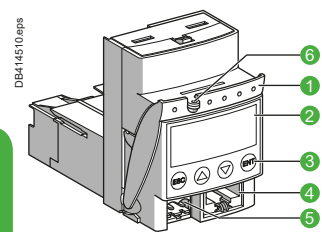

LUCM●●BL control unit

- 1 Extraction and locking handle.
- 2 Built-in LCD display (2 lines, 12 characters).
- 3 4 button keyboard.
- 4 RJ45 connector for RS485 Modbus communication
- 5 Connector for external 24 V DC power supply.
- 6 Sealing of locking handle.

Control units for power bases with advanced control

LUCB, LUCC, LUCD control and diagnostic units

Motor protection, fault diagnostic.

Protection against

- overload: $14.2 \times I_r$ (setting current).
- Simulation of an overload by depressing the test push button.
- short circuit: $13 \times I_r$ max (max setting current).
- missing or unbalanced phases.
- insulation fault (protection of equipment only).

Overload alarm management:

- locally: with one of the LUF family module
- Remotely: with LULC031, LULC033, LULC07, LULC08, LULC09 or LULC15 (thermal alarm only) communication module.

Reset:

- manual
- automatic, with a communication module.

LUCM multifunctional control unit

Motor protection, operational values display and diagnostic.

To be associated with 24 V DC coil only.

LUCM●●BL: tripping class 5 to 30, single phase, three phase

Same functions as LUCB●●●● with complementary functions:

- in working mode: display of electrical values, setting parameters and events
- in configuration mode: display of protection and alarm settings.

These functions are available for local display on a display panel, and for remote display via a RJ45 Modbus connector.

LUCM is not compatible with LUB38.

Note: a 24 V DC power supply is required during the configuration process.

TeSys U



LUCM12BL

Maximum standardized power ratings of 3 phases motors 50/60 Hz				Lip_in mounting on the power base - Rating	DBA14489.eps 	Protection type: - overload - short-circuit - Main power fault - alarm			DBA14504.eps
400/440 V	500 V	600 V	Setting range			Class 10	Class 10	Class 20	
kW 1P 3P	kW 3P	kW 3P	A	A	3P	1P	3P	Class 5...30 1 - 3P	
-	0.09	-	-	0.15...0,6	12 and 32	LUCB6●●	LUCC6●●	LUCD6●●	LUCM6BL
0.09	0.25	-	-	0.35...1,4	12 and 32	LUCB1X●●	LUCC1X●●	LUCD1X●●	LUCM1XBL
0.55	1.5	2.2	3	1.25...5	12 and 32	LUCB05●●	LUCC05●●	LUCD05●●	LUCM05BL
2.2	5.5	5.5	9	3...12	12 and 32	LUCB12●●	LUCC12●●	LUCD12●●	LUCM12BL
4	7.5	9	15	4.5...18	32	LUCB18●●	LUCC18●●	LUCD18●●	LUCM18BL
7.5	15	15	18.5	8...32	32	LUCB32●●	LUCC32●●	LUCD32●●	LUCM32BL
18.5	18.5	22	9.5...38	38		LUCB38●● ⁽¹⁾		LUCD38●● ⁽¹⁾	

Cial. ref. of the control unit: replace dots by the coil code.

Coil voltage (V)	24~	24~	48...72 ~ and 48~	110...220 ~ and 110...240~
Coil code	BL	B	ES	FU

Magelis XBT NU HMI terminal (optional)

Provides display and modification of the LUCM multifunctional control unit settings. Modbus protocol – dialog up to 8 TeSys U⁽²⁾- Pre-loaded application and alarm pages, multi-language.



XBTNU400

Designation	References
Magelis TeSys U terminal	XBTNU400
Connecting cable XBTNU400 to LUCM ●●BL, L = 2.50 m ⁽²⁾	XBTZ938

⁽¹⁾ With BL or FU code only.

⁽²⁾ A Modbus hub or - junction must be used when connecting several TeSys U.

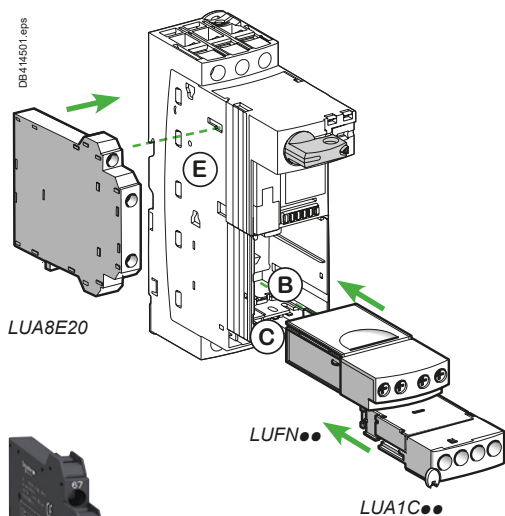

LUA8E20



LUFN02



LUA1C20



LUFV2



LUFW10



LUFDH11



LUFDA01



LUFDA10

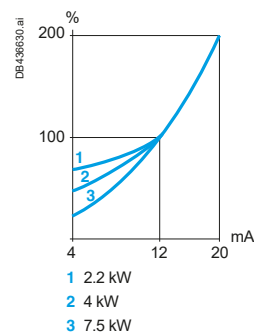

LUFV2 typical response curve

Characteristics:
pages A4/48 to A4/52

Schemes:
pages A4/62 to A4/64

Signaling module and blocks

They provide dry contacts of Normally Open (NO) or Normally Closed (NC) type for signaling purpose. The monitored status can be either the motor running status or the protection device status, depending on the commercial reference of the module or block.

Common electrical characteristics

Standard operating voltage: 24...250 V AC/DC.

Maximum current: 5 A.

Compatibility - Positioning

The signaling module and blocks can be used in any power base

LUA8E20 is clipped on the E side of the power base

LUFN11, LUFN02, LUFN02 inserted into B cavity

LUA1C20, LUA1C11 inserted into C cavity

Note: B and C cavities may be already used for reverser-starter, communication.

Signaling module and blocks	Output	References
Module	1 NO + 1 NC	LUFN11
Motor running status: ON / OFF	2 NC	LUFN02
	2 NO	LUFN20
Block	2 NO	LUA1C20
Protection status: OPEN / CLOSED (OF) STANDBY / TRIPPED (SD)	1 NO + 1 NC	LUA1C11
Side block	2 NO	LUA8E20
Protection status: OPEN / CLOSED (OF)		

Function modules

They provide analog output or dry contacts of Normally Open (NO) or Normally Closed (NC) type for measurement or signaling purpose.

Common electrical characteristics

Standard operating voltage: 24...250 V AC/DC.

Maximum current: 5 A.

Compatibility - Positioning

The function modules can only be used in a LUB120, LUB320 or LUB380 power base, in cavity B.

Function modules	Output type	References
Electrical value: average current in each phase. The signal is the image of the percentage of I_n . External 24 V DC power supply needed	Analog: 4-20 mA	LUFV2
Contact closes if average current in the phases = 105 % of I_n	1 NO	LUFW10
Contacts change state if tripping is caused by overload	1 NO + 1 NC	LUFDH11
Contact opens if overload tripping is reset with control pad or remotely	1 NC	LUFDA01
Contact closes if overload tripping is reset with control pad or remotely	1 NO	LUFDA10



LUFC00

Auxiliary parallel wiring module ⁽¹⁾

Auxiliary parallel wiring module for Modicon Telefast system

Inputs

They collect the FWD, REV controls from an automation process.

An RJ45 parallel port is used, for connection to the 24 V DC outputs of a PLC.

Outputs

They give the position of the control pad and the state of the poles,

They provide 24 V DC controls to the LUB120, 320 or 380 power base coil via the LU9BN11C adapter (A2, A1) or to the LU2B12, 32, 38 power base coil with a LU9MRC adapter (A2, A1, A3).

Compatibility - Positioning

The parallel wiring module can only be used in any TeSys U power base,

with LUC●●● control unit with coil voltage

Compatible with:

- Modicon TM3 (map I/O controllers for RJ45 M221, M241, M25)
- Modicon STB modules (I/O for automation island)
- Modicon Telefast (interfaces RJ45/HE10).

The parallel wiring module is inserted in cavity B.

Note: the parallel wiring module must be connected to a LU9G02 or LU9G03 Telefast distribution

Note: more details on parallel wiring page A4/16.

Designation

TeSys U power base parallel wiring module

References

LUFC00

Communication modules

Communication modules

These modules send the control pad position and pole state to a communicating system (PLC, monitoring system,...)

They collect the Forward, Reverse motor controls from an automation process.

The status and controls are coded according to an industrial communication protocol, depending on the communication module.

Bus cable connection, external power supply by crew clamp terminals.

Connector for coil control (to A1-A3-A2) via a prewired connection (LU9BN● for 1-direction control, LU9MR● for 2-direction control)

Compatibility - Positioning

The communication modules can only be used in a LUB120, LUB320 or LUB380 power base, in cavity B.

Designation

TeSys U Modbus communication module

References

LULC033

TeSys U AS-Interface communication module

ASILUFC51

TeSys U Profibus DP communication module

LULC07

TeSys U CANopen communication module

LULC08

TeSys U DeviceNet communication module

LULC09

TeSys U Advantys STB communication module

LULC15

Note: Ethernet communication can be achieved with LULC033 + ConneXium TeSys Port (ref. TCSEQM113M13M)

Note: more details on bus-type communication page A4/21.

Prewired connectors

They provide the necessary electrical link between a parallel or communication module and the coil supply connector, on the power base or reverser block. Thus, ON-OFF (1 direction) or FORWARD-REVERSE (2 direction) controls can be achieved.

Prewired connection

Prewired connection			References	Compatibility with modules
1 direction	Short cable	Side connection	LU9BN11C	LUFC00, LULC033, ASILUFC51
		Bottom connection	LU9BN11L	LULC07, 08, 09, 15
2 direction	Long cable	Side connection	LU9MRC	LUFC00, LULC033, ASILUFC51
		Bottom connection	LU9MRL	LULC07, 08, 09, 15



LULC033



ASILUFC51



LULC07



LULC15



LU9BN11C



LU9BN11L



LU9MRC



LU9MRL

PB 106090 eps



TeSys U

Point-to-point wiring

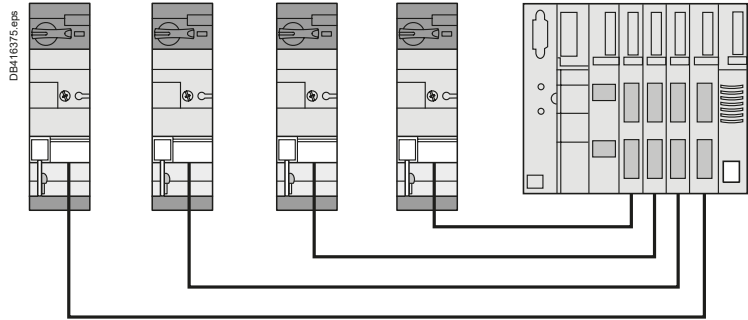

- The control inputs and signaling outputs of the starter are grouped in a single socket, usually RJ45. They are individually connected to PLC outputs and inputs.
- The wires run in parallel in a multicore cable equipped with a multipin connectors, RJ45 in the case of Telefast type system.
- 3 parallel wiring systems are available:
 - Modicon TM3, based on a RJ45 I/O module for M221, M241, M25 PLC
 - Modicon STB, based on I/O modules for automation island
 - Modicon Telefast: RJ45 / HE10 interfaces.
- Simple way of proximity wiring. Quick cabling. It is suitable for machine control panels when a large number of TeSys U starter-controller are installed.

informations

- The control and signaling terminals of the starters are connected to the output and input terminals of a PLC. No specific connectors or cables are required.
- Conventional wiring mode, without optimization of the cabling time. May be suitable when a very small number of starters is used, with a very small number of links.

Parallel cabling systems

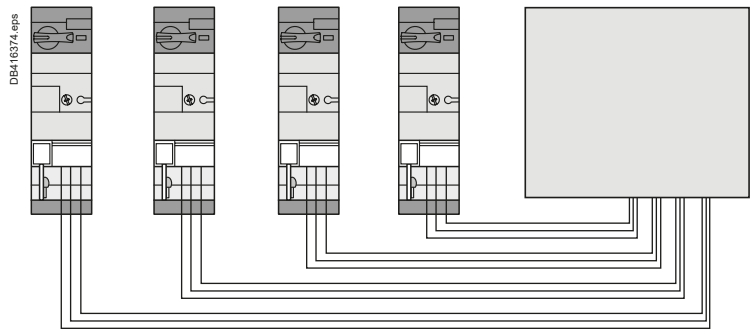

Integration in the Modicon TM3 wiring system

The TeSys U starter-controller are directly connected to a I/O module equipped with RJ45 connectors.

- 1 Modicon M221, M241, M251 PLC's
- 2 TM3XTY I/O module for 4 starters
- 3 LU9R●● cables with RJ45 connectors,
- 4 LUFC00 module for TeSys parallel connection (1 or 2 direction of rotation).

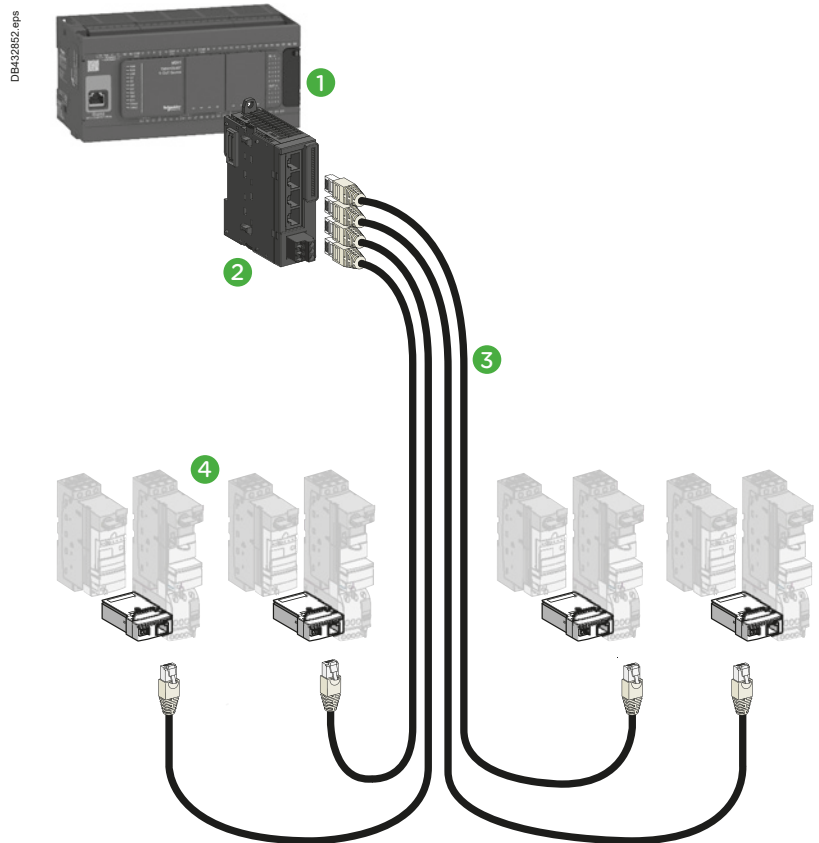

Integration in the Modicon Advantys STB system

Advantys STB is a solution for remote I/O modules.

These communicate with the Modicon PLCs range thanks to a serial liaison, using the Advantys STB protocol.

In this example an Advantys I/O module is used to facilitate wiring.

Each of its four terminals receives a preassembled RJ45 cable connected to a TeSys U starter-controller.

- 1 TeSys U LUB120, 320 or 380 power base (equipped with 24 V DC LUC●●●●BL control modules)
- 2 TeSys module for parallel RJ45 wiring: LUFC00 + LU9BN11C (one direction) or LU9MRC (2 directions for LU2B12, 32 or 38 power base)
- 3 RJ45 cables (2 connectors):
 ≤ 3 m: LU9R●●
 > 3 m: 490 NTW000●● (5, 12, 40 or 80 m)
- 4 PLC: Modicon range
- 5 I/O Modicon Advantys module: STB EPI 2145K

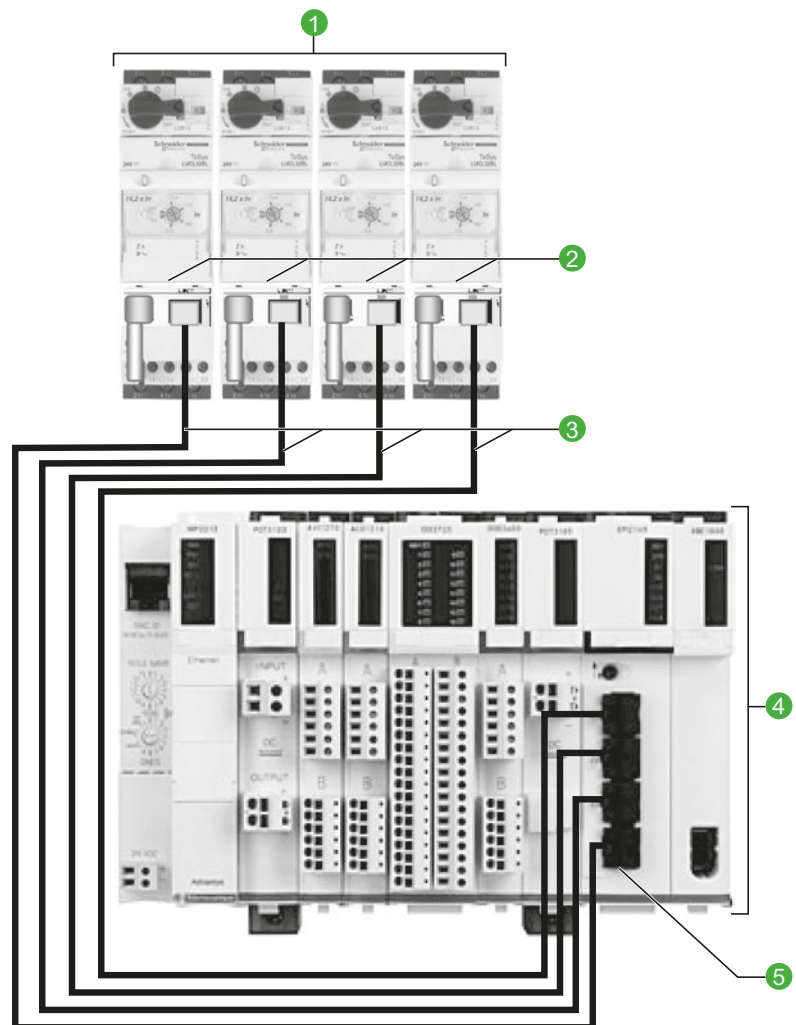

Integration in the Modicon Telefast system

The wiring hubb **LU9G0●** facilitates the connection to Modicon Premium PLCs.

It adapts RJ45 connectors to HE10 available on the Telefast I/O modules.

Connection: up to 8 TeSys U per hubb.

- ① TeSys U LUB120, 320 or 380 power base (equipped with 24 V DC LUC●●●●BL control units)
- ② TeSys Module for parallel wiring RJ45: LUFC00 + LU9BN11C (one direction) or LU9MRC (2 directions for LU2B12, 32 or 38 power base)
- ③ RJ45 cables (2 connectors):
 ≤ 3 m: LU9R●●
 > 3 m: 490 NTW000●● (5, 12, 40 or 80 m)
- ④ Telefast RJ45 / HE10 splitter box: LU9G02 or LU9G03 (different TeSys U connection capacities)
- ⑤ HE10 cables (2 connectors): TSXCDP●●●
- ⑥ PLC: Modicon Premium range
- ⑦ I/O module: TSX DMY 28FK

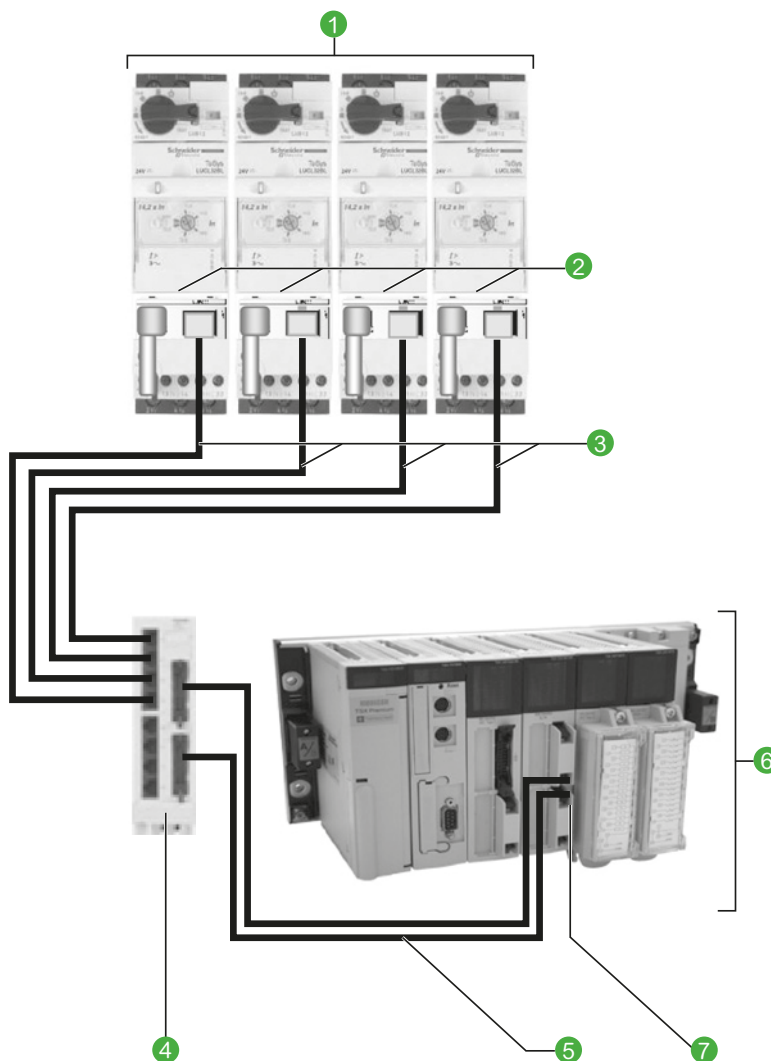

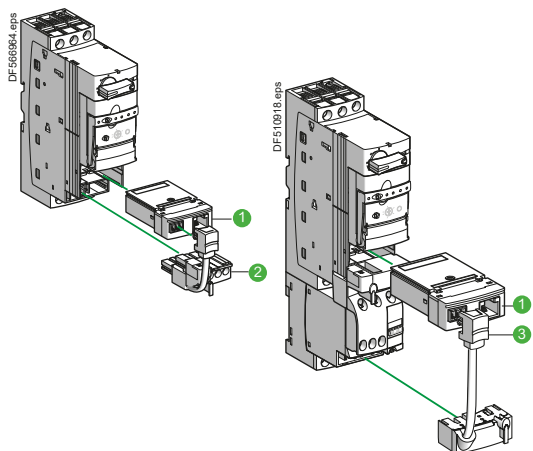

Components for connection of a starter - 1 direction of rotation

Designation	Reference
① Parallel connection module, RJ45 output 2 coil control inputs, 3 signal outputs	LUFC00
② Pre wired connector, one direction of rotation, for LUB120, 320 or 380 power base coil connection and one contact for emergency stop	LU9BN11C

Components for connection of a starter - 2 directions of rotation

Designation	Reference
① Parallel connection module, RJ45 output	LUFC00
③ Pre wired connector, 2 directions of rotation, for LU2B12, 32 or 38 power base coil connection and one contact for emergency stop	LU9MRC

TeSys U



LU9G02



LU9G03

Telefast RJ45/ HE10 splitter box

Designation	Reference
Splitter box Connection to TeSys U: 4 RJ45 connectors: for 1 to 4 TeSys U, 1 or 2 directions 4 RJ45 connectors: for 1 to 4 TeSys U, 1 direction Connection to PLC: 1 x HE10 connector - 20 channels, for pole status, alarms 1 x HE10 connector - 20 channels, for control. 24 V DC auxiliary power supply required	LU9G02
Splitter box Connection to TeSys U: 8 RJ45 connectors: for 1 to 8 TeSys U, 1 or 2 directions Connection to PLC: 1 x HE10 connector - 20 channels, for pole status, alarms 1 x HE10 connector - 20 channels, for control. 24 V DC auxiliary power supply required.	LU9G03

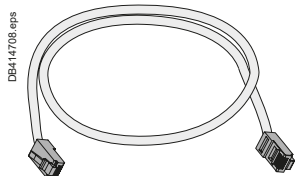

RJ45 cables.

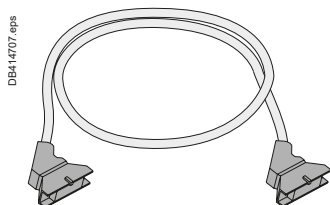

HE10 cables.

RJ45 connection cables, with 2 RJ45 connectors

0.3 m	LU9R03
1 m	LU9R10
3 m	LU9R30

HE10 connection cables, with 2 HE10/20 way connectors

Section: AWG 22 / 0.324 mm ²	
0.5 m	TSXCDP053
1 m	TSXCDP103
2 m	TSXCDP203
3 m	TSXCDP303
5 m	TSXCDP503
Section: AWG 28 / 0.080 mm ² (flat cable)	
1 m	ABFH20H100
2 m	ABFH20H200
3 m	ABFH20H300

HE10 connection cables, with 1 x HE10/40 way connector (PLC side) and 1x HE10/20 way connector (Splitter box side)

Section: 0.324 mm ²	
0,5 m	BMXFCC053
1 m	BMXFCC103
2 m	BMXFCC203
3 m	BMXFCC303
5 m	BMXFCC503
10 m	BMXFCC1003

Cable with stripped wires (PLC side) 1 x HE10/20 ways connector (Splitter box side)

Section: AWG 22 / 0.324 mm ²	
3 m	TSXCDP301
5 m	TSXCDP501

PB10592.eps



> Application functionality, topology

1 Geographically expanded process

Many motors are scattered on the site, the process control requires individual control to ensure safety and proper operation.

TeSys U is a suitable communicating actuator. The integration of a bus communication module in the starter-controller saves space in the control board and simplifies wiring, compared to solutions based on conventional components (circuit breaker + contactor).

2 Application: automatic motor control / monitoring

Thanks to a communication bus, starter-controllers are part of an automation system controlled by a PLC and (or) various communicating controllers.

These equipment can then share the status and alarm information related to each motor control and perform specific treatments.

3 Bus-type connection

This type of connection allows different topologies (star, ring ...) and supports various protocols dialogue. It is therefore recommended for geographically expanded process, in order to to simplify wiring and ensure multiple-controller management.

- The bus wiring interconnects TeSys U starters controllers and components of the installation via a single the cable.
- Commands and status are coded according to the selected protocol and transmitted on the communication bus.
- This wiring is simple, usually a shielded (or not) pair of wires, suitable for monitored automation, regardless of the number of TeSys U and their locations.

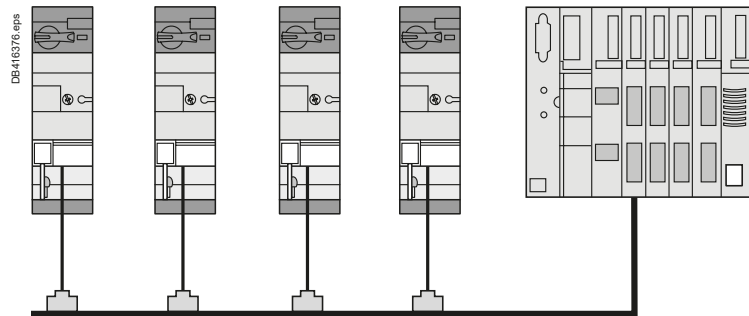

Available TeSys U status and controls via a communication module

Control unit	LUCA	LUCB LUCC LUCD	LUCM
Starter status (ready, running, fault)	■	■	■
Start and Stop commands	■	■	■
Thermal overload alarm		■	■
Remote reset via the bus		■	■
Indication of motor load		■	■
Fault signalling and differentiation		■	■
Remote programming and monitoring of all functions			■
"Log" function			■
"Monitoring" function			■
Alarms (overcurrent, ...)			■

Network

Architecture

Component references

AS Interface

Cabling system for rapidly connecting sensors and actuators to the controller. A single cable provides both data transmission and power to sensors.

Details page

[A4/24](#)

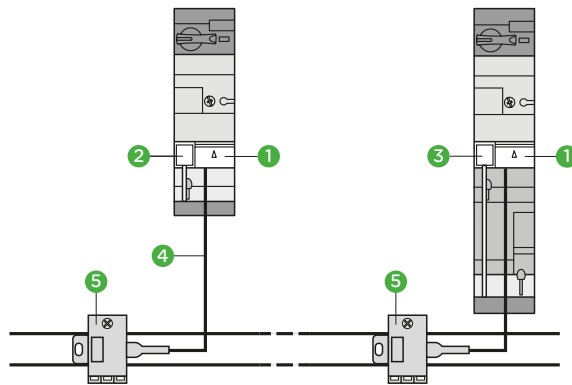

- 1 ASILUFC5 or ASILUFC51
- 2 LU9BN11C
- 3 LU9MRC
- 4 XZCG0142
- 5 TCSATV01N2

CANopen

Etoile

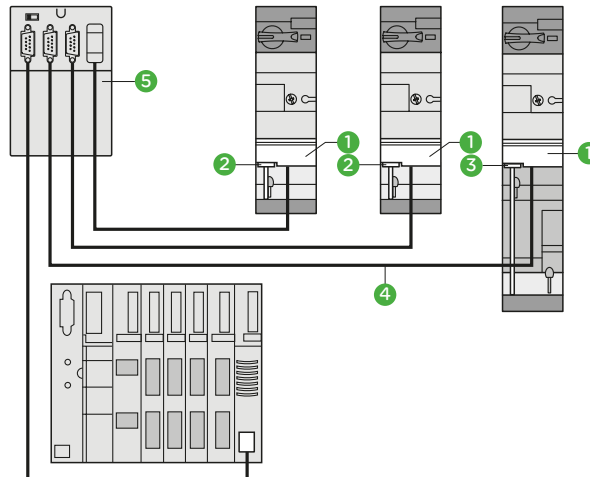

- 1 LULC08
- 2 LU9BN11L
- 3 LU9MRL
- 4 TSXCANC●●●
- 5 TSXCANTDM4
- 6 TSXCPP110

Bus

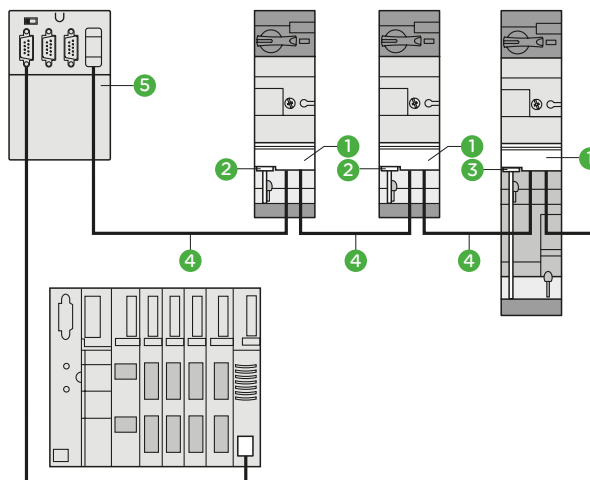

Details page

[A4/25](#)

Network	Architecture	Component references
<p>Modbus</p> <p>Details page A4/26</p>		<ol style="list-style-type: none"> 1 LULC033 2 LU9BN11C 3 LU9MRC 4 VW3A8306R... 5 LU9GC3 6 VW3A8306TF
<p>Advantys STB</p> <p>Starter-controllers communicate using ADVANTYS STB protocol to fit into a remote I/O architecture.</p> <p>Details page A4/27</p>		<ol style="list-style-type: none"> 1 LULC15 2 LU9BN11L 3 LU9MRL 4 LU9RDD... 5 LU9RCD 6 STBxBE1100
<p>Profibus-DP (Decentralized Peripherals)</p> <p>is used for connecting actuators and sensors to a central controller for applications in industrial production. The standard bus provides a number of diagnostic means</p> <p>Details page A4/28</p>		<ol style="list-style-type: none"> 1 LULC07 2 LU9BN11L 3 LU9MRL 4 LU9RPB010 LU9RPB100 LU9RPB400 5 LU9AD7 6 LU9GC7
<p>DeviceNet</p> <p>Details page A4/29</p>		<ol style="list-style-type: none"> 1 LULC09 2 LU9BN11L 3 LU9MRL

TeSys U

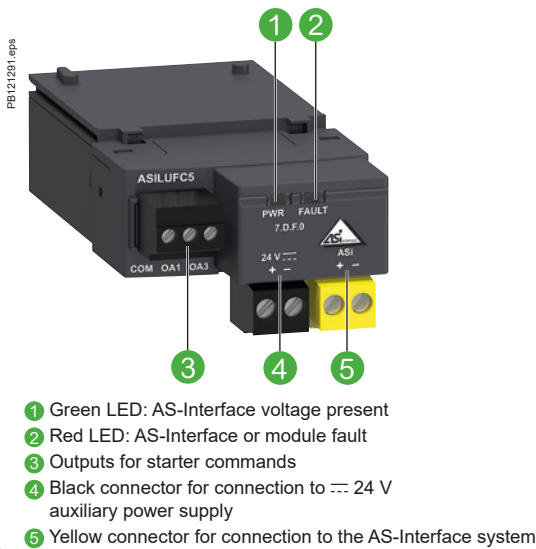

The ASILUFC5 communication module, combined with the power base and control unit is used to control TeSys U starters-controllers via DeviceNet bus.
 The LULC09 communication module is slave type.

Module Specifications

I/O terminal block

- Powered by external 24 V DC (power supply not included):
- 2 x configurable inputs for binary sensors
- 1 x 24 V DC output - 0.5 A local auxiliary command.

Connectors

- For TeSys U 24 V DC coil (common, direction 1, direction 2).
- For AS-Interface bus.

Signaling

- Module Status - Error - 24 V, by LED.

TeSys components

Description	Mark	Max number of slaves	References
AS-Interface communication module	1	31	ASILUFC5
		62	ASILUFC51
Pre-wired connector: coil - LUB powerbase	2	-	LU9BN11C
Pre-wired connector: coil - LUB2B powerbase	3	-	LU9MRC

Connection of the communication module

By a "Y" cable with:

- TeSys U side, 2 connectors (bus + power),
- Bus side, one connector to be connected to the AS-Interface TCSATV01N2 tap-off.

Description	References
AS-Interface / TeSys U branch cable, L = 2 m	XZCG0142
AS-Interface Tap-off	TCSATV01N2

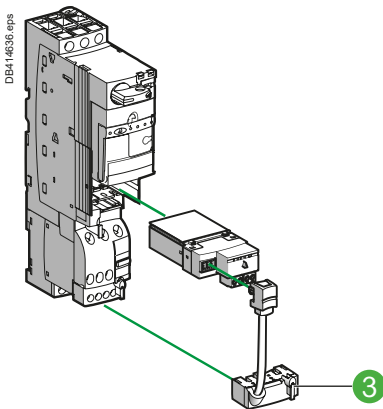
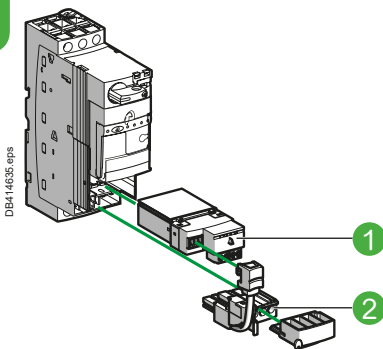

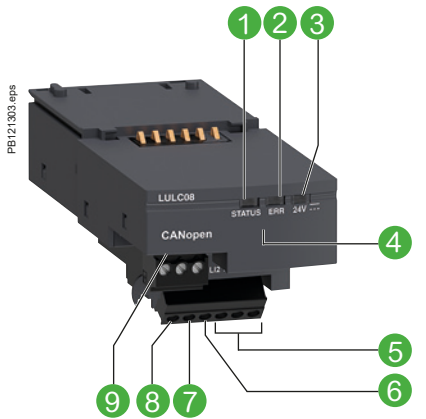

- 1 LED indicating module status
- 2 Fault signalling LED
- 3 LED indicating 24 V supply ON for outputs OA1, OA3 and LO1
- 4 SUB-D connector for bus link
- 5 24 V supply connection
- 6 Discrete input
- 7 Discrete input
- 8 Discrete output
- 9 Outputs for starter commands

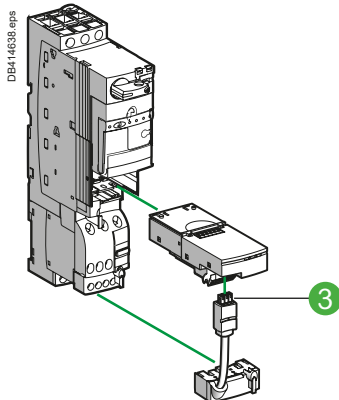
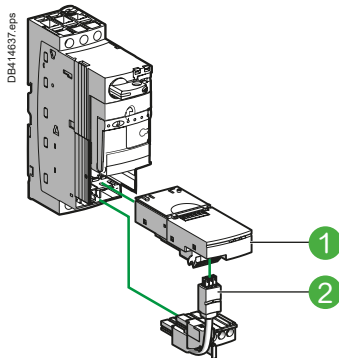

The LULC08 communication module, combined with the power base and control unit is used to control TeSys U starters-controllers via CANopen bus. The LULC08 communication module is slave type.

Module Specifications

I/O terminal block

- Powered by external 24 V DC (power supply not included):
 - 2 x configurable inputs for binary sensors
 - 1 x 24 V DC output - 0.5 A local auxiliary command.

Connectors

- For TeSys U 24 V DC coil (common, direction 1, direction 2).
- For CANopen bus.

Signaling

- Module Status - Error - 24 V, by LED.

Tesys components

Description	Item	References
CANopen communication module	1	LULC08
Pre-wired connector: coil - LUB powerbase	2	LU9BN11L
Pre-wired connector: coil - LUB2B powerbase	3	LU9MRL

Compatibility of CANopen communication module with control units

LUCA ●●BL / B ●●BL / C ●●BL / D ●●BL	All versions marketed after 2T0481 ⁽¹⁾
LUCM●●BL	All versions ≥ V3.2
LUCMT1BL	All versions ≥ V3.2

(1) This "date code" is made up as follows:
 2T or 2C: factory code.
 04, 05, 06 and so on: year of manufacture.
 08: week.
 1: 1st day of the week.

How to get information on the design of a CANopen architecture and the choice of network accessories

Consult the library of downloadable documents on schneider-electric.com by searching on the name of the communication protocol.



LULC033

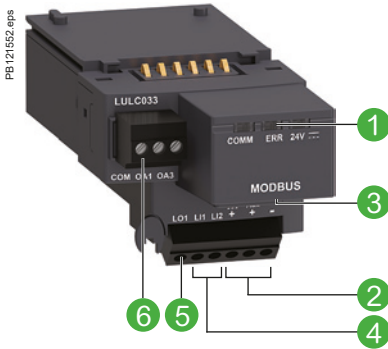

- 1 Module status signalling LED
- 2 24 V supply connection
- 3 RJ45 connector for RS485 Modbus link
- 4 2 discrete inputs
- 5 1 discrete output
- 6 Outputs for starter commands

TeSys U

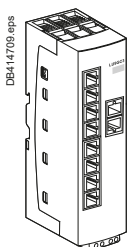
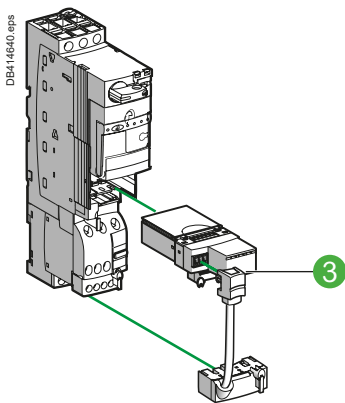
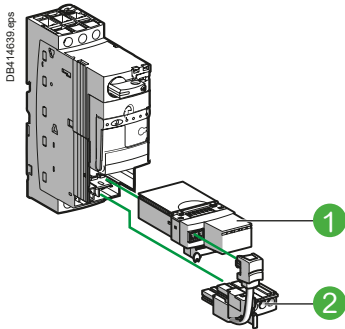

LULC033 communication module, combined with the power base and control unit is used to control TeSys U starters-controllers via Modbus.

Module Specifications

I/O terminal block

- Powered by external 24 V DC (power supply not included):
- 2 x configurable inputs for binary sensors (on LULC033 only)
- 1 x 24 V DC output - 0.5 A local auxiliary command.

Connectors

- For TeSys U 24 V DC coil (common, direction 1, direction 2).
- RJ45, For Modbus line.

Signaling

- Module Status - Error - 24 V, by LED.

Tesys components

Description	Item	Bin. input	References
Modbus communication module	1	2	LULC033
Pre-wired connector: coil - LUB powerbase	2	-	LU9BN11C
Pre-wired connector: coil - LUB2B powerbase	3	-	LU9MRC

Modbus hub

Description	Length (m)	References
Modbus communication distributor	-	LU9GC3
Cables fitted with 2 x RJ45 connectors	0.3	VW3A8306R03
	1	VW3A8306R10
	3	VW3A8306R30
Tees derivations	0.3	VW3A8306TF03
	1	VW3A8306TF10

Description	References
RS 485 line terminator	VW3A8306R

Compatibility of Modbus communication modules

Communication modules (software version)		LUCLC033 from V2.1	LUCLC033 from V2.2
Power base	LUB●● / LU2B●2	■	■
	LUTM●●BL	■	■
Control unit	LUCA●●BL		■
	LUCB●●BL		■
	LUC●●BL		■
	LUCD●●BL		■
	LUCM●●BL		■ ⁽¹⁾
	LUCBT●●BL	■	
	LUCDT●●BL	■	
	LUCMT●●BL	■	

(1) Except LUCM●●BL V1.04 and V1.06.

How to get information on the design of a Modbus architecture and the choice of network accessories

Consult the library of downloadable documents on schneider-electric.com by searching on the name of the communication protocol.

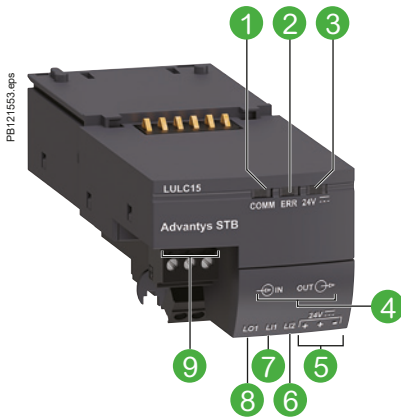

- 1 Two-colour LED indicating module status
- 2 Fault signalling LED
- 3 LED indicating that 24 V supply is ON
- 4 Bus connectors
- 5 24 V supply connection
- 6 Discrete input
- 7 Discrete input
- 8 Discrete output
- 9 Outputs for starter commands

Communication module LULC15 allows direct connection of TeSys U starter-controllers and controllers on an Advantys STB island, between two segments or at the end of a segment. The starter-controller will then be able to make use of the services provided by Advantys STB: self-addressing, autobaud, fallback positions.

Module Specifications

I/O terminal block

- Powered by external 24 V DC (power supply not included):
- 2 x configurable inputs for binary sensors (on LULC033 only)
- 1 x 24 V DC output - 0.5 A local auxiliary command.

Connectors

- For TeSys U 24 V DC coil (common, direction 1, direction 2).
- For Advantys STB bus.

Signaling

- Com - Error - 24 V, by LED.

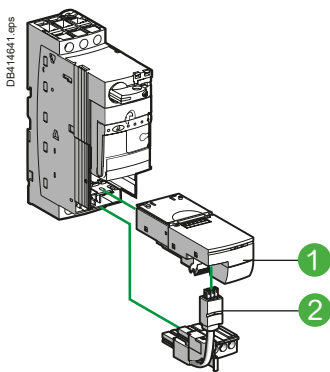

LUB + LULC15 + LU9BN11L

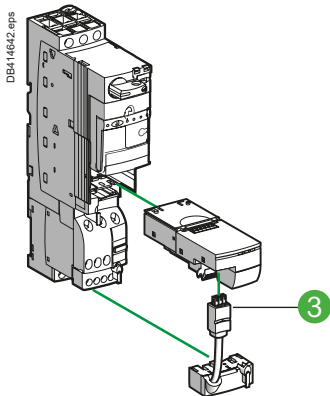

LU2B + LULC15 + LU9MRL

TeSys components

Description	Item	References
Advantys STB communication module	1	LULC15
Pre-wired connector: coil - LUB powerbase	2	LU9BN11L
Pre-wired connector: coil - LUB2B powerbase	3	LU9MRL

Cables

Description	Length (m)	References
Cables fitted with connectors, one straight and one elbowed	0.3	LU9RCD03
	1	LU9RCD10
	3	LU9RCD30
	5	LU9RCD50
Cables fitted with two straight connectors	0.3	LU9RDD03
	1	LU9RDD10
	3	LU9RDD30

Compatibility of Advantys STB communication module with control units

LUCA●●BL / B●●BL / C●●BL / D●●BL	All versions marketed after 2T0481 ⁽¹⁾
LUCM●●BL	All versions ≥ V3.2
LUCMT1BL	All versions ≥ V3.2

(1) This "date code" is made up as follows:
 2T or 2C: factory code.
 04, 05, 06 and so on: year of manufacture.
 08: week.
 1: 1st day of the week.

How to get information on the design of a Advantys STB architecture and the choice of network accessories

Consulter la librairie des documents téléchargeables sur le site schneider-electric.com en faisant une recherche sur le nom du protocole de transmission.

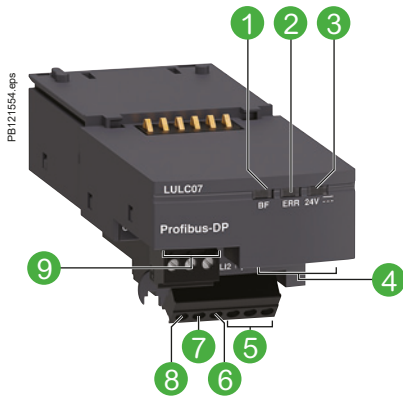

- 1 Two-colour LED indicating module status
- 2 Fault signalling LED
- 3 LED indicating 24 V supply ON for outputs OA1, OA3 and LO1
- 4 SUB-D connector for bus link
- 5 24 V supply connection
- 6 Discrete input
- 7 Discrete input
- 8 Discrete output
- 9 Outputs for starter-controller commands (non-reversing and reversing)

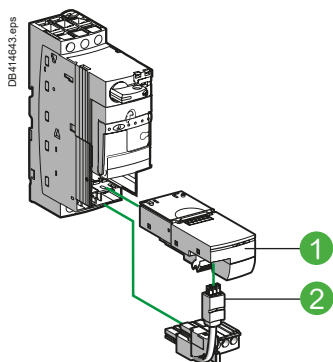

LUB + LUC...BL + LULC07 + LU9BN11L

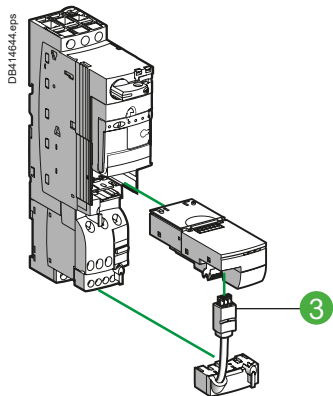

LU2B + LUC...BL + LULC07 + LU9MRL

When used in conjunction with the power base and control unit, communication module LULC07 allows TeSys U starter-controllers to be controlled via Profibus DP (Deported Periphery) bus. Communication module LULC07 is of the slave type.

Module Specifications

I/O terminal block

- Powered by external 24 V DC (power supply not included):
 - 2 x configurable inputs for binary sensors
 - 1 x 24 V DC output - 0.5 A local auxiliary command.

Connectors

- For TeSys U 24 V DC coil (common, direction 1, direction 2).
- For Profibus DP bus.

Signaling

- Com - Error - 24 V, by LED.

TeSys components

Description	Item	References
Profibus DP communication module	1	LULC07
Pre-wired connector: coil - LUB powerbase	2	LU9BN11L
Pre-wired connector: coil - LUB2B powerbase	3	LU9MRL

Components for connection to the bus and to the installation

The 24 V DC -Aux supply to Profibus DP modules LULC07 must pass through power supply module LU9GC7.

LULC07 modules must be connected to the LU9GC7 splitter box in order to be powered.

The number of TeSys U starter-controllers that can be powered by an LU9GC7 module is limited by the maximum current (1.5 A) which it can deliver.

The 24 V supply for the inputs/outputs must be provided separately..

Description	Length (m)	References
Profibus DP power supply module	-	LU9GC7
Profibus DP connector	-	LU9AD7
Profibus DP cables 2-wire	100	TSXPBSCA100
	400	TSXPBSCA400
Profibus DP cables 4-wire	10	LU9RPB010
	100	LU9RPB100
	400	LU9RPB400

How to get information on the design of a Profibus DP architecture and the choice of network accessories

Consult the library of downloadable documents on schneider-electric.com by searching on the name of the communication protocol.

TeSys

TeSys U All-in-one motor starters - DeviceNet communication module

Product references

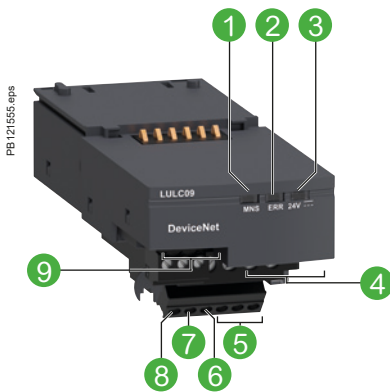

- 1 LED indicating module status
- 2 Fault signalling LED
- 3 LED indicating $\overline{\text{24 V}}$ supply ON for outputs OA1, OA3 and LO1 and 24 V bus
- 4 DeviceNet connector for bus link
- 5 $\overline{\text{24 V}}$ supply connection
- 6 Discrete input
- 7 Discrete input
- 8 Discrete output
- 9 Outputs for starter-controller commands (non-reversing and reversing)

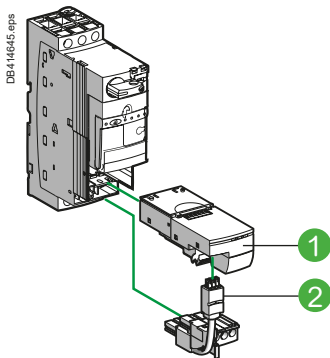

LUB + LUC●●●BL + LULC07 + LU9BN11L

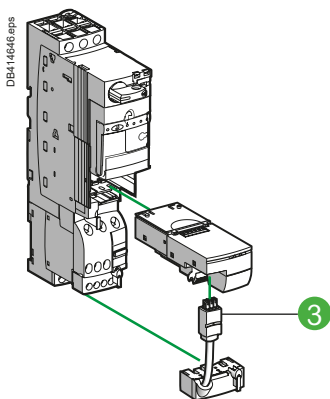

LU2B + LUC●●●BL + LULC07 + LU9MRL

When used in conjunction with the power base and control unit, communication module LULC09 allows TeSys U starter-controllers to be controlled via DeviceNet bus. Communication module LULC09 is of the slave type.

Module Specifications

I/O terminal block

- Powered by external 24 V DC (power supply not included):
- 2 x configurable inputs for binary sensors
- 1 x 24 V DC output - 0.5 A local auxiliary command.

Connectors

- For TeSys U 24 V DC coil (common, direction 1, direction 2).
- For DeviceNet bus.

Signaling

- Com - Error - 24 V , by LED.

Tesys components

Description	Item	References
DeviceNet communication module	1	LULC09
Pre-wired connector: coil - LUB powerbase	2	LU9BN11L
Pre-wired connector: coil - LUB2B powerbase	3	LU9MRL

How to get information on the design of a DeviceNet architecture and the choice of network accessories

Consult the library of downloadable documents on schneider-electric.com by searching on the name of the communication protocol.



PB 121537 eps



TeSys U



DF526109-17-M eps



561512 eps

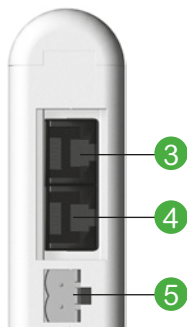

Introduction

LUFU communication gateways allow connection between the Modbus serial link and Fipio, Profibus DP or DeviceNet field buses.

After configuration, these gateways manage information which can be accessed by the Modbus serial link and make this information available for read/write functions (command, monitoring, configuration and adjustment) on the field buses.

An LUFU communication gateway consists of a box which can be clipped onto a 35 mm omega rail, allowing connection of up to 8 Slaves connected on the Modbus serial link.

Example of architecture

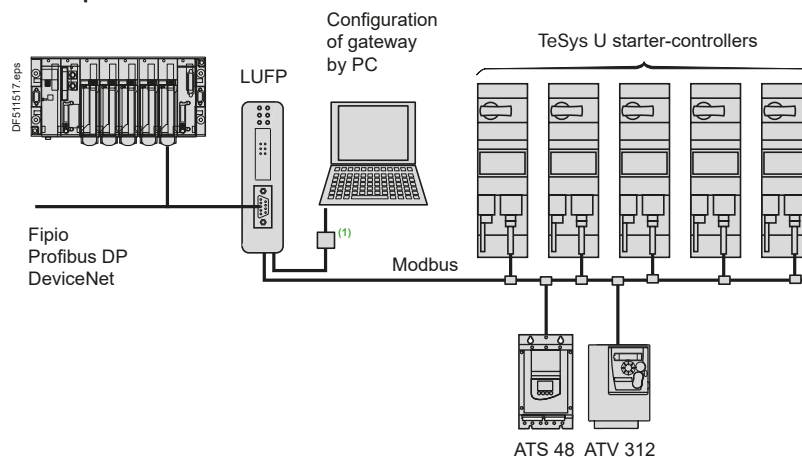

Communication gateway LUFU

Description	Reference
Fipio / Modbus gateway	LUFU1
Profibus DP / Modbus gateway	LUFU7
DeviceNet / Modbus gateway	LUFU9

Description

Front panel of the product

- ① LED indicating :
 - communication status of the Modbus serial links,
 - gateway status,
 - communication status of the Fipio, Profibus DP or DeviceNet bus.
- ② Connectors for connection to Fipio, Profibus DP or DeviceNet buses.

Underside of product

- ③ RJ45 connector for connection of the Modbus serial link
- ④ RJ45 connector for link to a PC
- ⑤ 24 V power supply

Software set-up

For the Fipio bus, software set-up of the gateway is performed using either PL7 Micro/Junior/Pro software or ABC Configurator software.

For the Profibus DP and DeviceNet buses, software set-up is performed using ABC Configurator.

This software is included in the TeSys U user's manual.

(1) Connection kit for PowerSuite software workshop.



LUALB1



LUALF1



LA9LB920

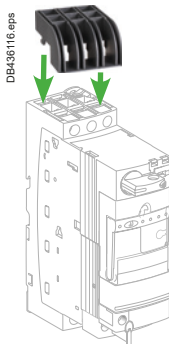

LU9SP0



LU9ET1S

Short-circuit current limiter block

To be connected in series and upstream of a TeSys U starter-controller. It increases its ability to withstand the short circuit current from 50 kA to 100 or 130 kA under 400 V.

Principle: under the action of a short-circuit, the opening of two contacts of each phase of the limiter creates a resistive arc. The current then decreases to a value tolerable by a TeSys U power base.

Limiter blocks and accessories

Description	Breaking capacity Iq (kA)		Ie (A)	Ith (A)	Mounting	Unit reference
	≤ 440 V	690 V				
Limiter-disconnector (1 x LUALF1 cartridge supplied)	130	70	-	32	Direct on power base up to 15 kW/32 A	LUALB1 ⁽¹⁾
Limiter limiter cartridge for LUALB1	100	35	32	63	Separate	LA9LB920 ⁽²⁾
	130	70	-	-	Limiter-disconnector	LUALF1

(1) Must be connected to one power base only.

(2) Can be connected to multiple TeSys U power bases in parallel with limitation :

- Total Ith max 63 A
- Total nominal current (Ie) 32 A from motor with simultaneous start (LA9LB920 could not withstand higher inrush peak current)

Phase barrier

Ensures a complementary electrical insulation between phases.

690 V AC network: compulsory.

440 V AC network: compulsory when assembling a UL508 type E compliant motor starter (Self Protected Starter).

Description	Use	Mounting	Reference
Phase separator	LUB or LU2B 12 or 120 LUB or LUB2B 32 or 320 LUALB1	Live terminals L1, L2, L3	LU9SP0

Clip-in labels

Can be clipped on any TeSys U power base, on LU6MB0●● inverter block, and Linergy HK busbar system.

Marking accessory

Description	Sold by lot of	Reference per unit
Clip-in label 8 x 18 mm	100	LAD90

Safety-chain identification - Red label

The red sticker is dedicated to TeSys U LUCA, LUCB, LUCC, LUCD and LUCL control units.

Description	Reference per unit
Retrofit safety-chain identification sticker	LU9ET1S

TeSys

TeSys U All-in-one motor starters - Rotary handles

Product references

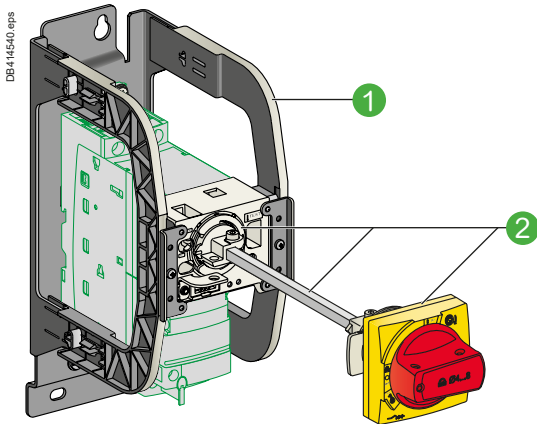

LU9APN21 mounting kit

Extended rotary handle

Allows a circuit breaker or a TeSys U starter-controller installed in back of an enclosure to be operated from the front panel.

The rotary handle can be black or red/yellow, IP54 or IP65. It includes a function for locking the circuit breaker or the starter in the O (OFF) or I (ON) position (depending on the type of rotary handle) by means of up to 3 padlocks with a shank diameter of 4 to 8 mm.

The extension shaft must be adjusted to the depth of the enclosure.

The IP54 rotary handle is fixed with a nut (Ø22) to make it easier to assemble.

Mounting kit

① TeSys U Power base bracket; its horseshoe shaped sides hold the rotary mechanism facing the original handle.

② Mechanism, shaft and handle; the shaft enters the handle attached to the door during closing.

Long shaft

■ to be cut to the required length. Equipped with a connection endpiece.

Shaft support plate for deep enclosure

■ Provides horizontal guiding of the shaft, when the door is open.

Spacer base (retrofit accessory)

■ Fixed on a side of the box, for heightening an GVAP●●● handle.

Handle

■ Delivered as a single unit, to be fitted on a side of the enclosure.

Note: references below are suitable for TeSys U power bases after 2004.

"Laser Square" Tool

■ On the principle of an angle extended with a laser beam, the "Laser Square" facilitates tracing the piercing marks on the door or the sides of an enclosure.

"Safety" stickers

■ Marking: Electrical hazard, etc.

TeSys U
PB100291.eps



GVAPA1 long shaft

PB100291.eps



GVAPK12 shaft support plate for deep enclosure

PB121242.eps



GVAPP1 spacer base (retrofit accessory)

PB100296.eps



GVAPR54 red handle, IP 54

PB100289.eps



GVAPYPHP external handle protection frame



GVAPL01 "Laser square" plotting tool

PB100297.eps

Description	Tripping indication	Reference
Mounting kit	Black handle, with error status, IP54	● LU9APN21
	Red handle, with error status, IP54	● LU9APN22
	Red handle, without error status, IP65	- LU9APN24
Separate elements	Long shaft = 315 mm	- GVAPA1
	Shaft (≥ 300 mm) support plate for deep enclosure	- GVAPK12
	Spacer base	- GVAPP1
	Black handle, IP54	● GVAPB54
	Red handle, IP54	● GVAPR54
	Black handle, IP65	● GVAPB65
Red handle, IP65	● GVAPR65	
Tool	"Laser square" plotting tool	GVAPL01
"Safety" stickers	French (x10)	GVAPSFR
	English (x10)	GVAPSEN
	German (x10)	GVAPSDE
	Spanish (x10)	GVAPSES
	Chinese (x10)	GVAPSCN
	Portuguese (x10)	GVAPSPT
	Russian (x10)	GVAPSRU
Italian (x10)	GVAPSIT	
External handle protection frame for TeSys U	Yellow frame	GVAPYPHP
	Black frame	GVAPBPHP

Dimensions:
page A4/61

A4/32

Life Is On

Schneider
Electric

TeSys

TeSys U All-in-one motor starters - Handle mounting kit for MCC drawers

Product references



PB11807_104.eps

MCC drawers (Motor Control Center)

The drawers are composed of:

- a fixed part, in the frame of the panel,
- a fully withdrawable part, integrating the protection, control and automation components.

With a height of 3/4/6/8/12/18/24/36 modules, they allow the assembling of motor protection/control feeders:

- Direct, one direction of rotation
- Direct, 2 directions of rotation
- Star-delta
- Dahlander (2 speeds)
- 2-speed, separate winding
- Motor drives from 0 to 500 kW
- Soft starters of 0 to 75 kW.

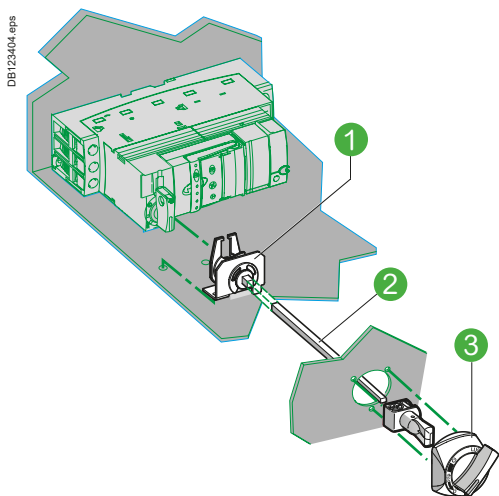

DB123404.eps

Mounting kit and handle for MCC drawer

Together, this provides manual control of a TeSys U starter-controller from the front face of the drawer.

As the clamping part on top of TeSys U control pad is open, the kit may be used on TeSys U power bases before 2005.

Mounting kit + small handle

Description	Item	Reference
Handle with mounting kit for MCC drawer	1 + 2 + 3	LU9AP20



PB121243.eps

TeSys U

TeSys

TeSys U All-in-one motor starters - Use with soft starter / Variable Speed Drive - LUCL control module

Product references

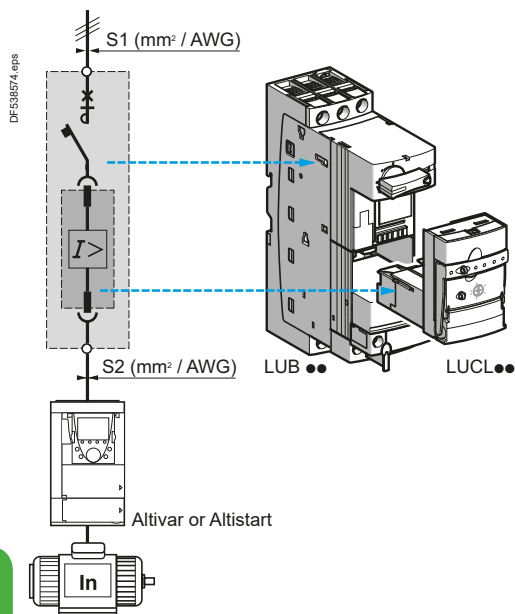

TeSys U



PB121270 eps



Introduction

When installed upstream of a variable speed controller or soft start unit, control unit LUCL●●, used in conjunction with an LUB12 or LUB32 power base, provides:

- isolation,
 - short-circuit protection of the motor starter.
- (variable speed controller-based or soft start unit-based motor starters).

Note: control unit LUCL, when used in conjunction with power base LUB12 or LUB32, conforms to standard IEC 60947-6-2.

Installation regulations

When the length of the cable between the TeSys U starter and the variable speed controller is more than 1.5 m, the c.s.a. of the cable between the variable speed controller and the TeSys U starter (S2) must be equal to the c.s.a. of the cable upstream of TeSys U (S1).

Description of LUCL magnetic control unit

- 1 Extraction and locking handle
- 2 Sealing of locking handle
- 3 Dial for magnetic adjustment of motor In
- 4 Locking of settings by sealing the transparent cover

References

Description	Line current of the variable speed controller or soft start unit	Reference ⁽¹⁾
A		
Magnetic control unit	0.15...0.6	LUCLX6●●
	0.35...1.4	LUCL1X●●
	1.25...5	LUCL05●●
	3...12	LUCL12●●
	4.5...18	LUCL18●●
	8...32	LUCL32●●

(1) Standard control circuit voltage:

Volts	24	48...72	110...240
⋮	BL ^{(2) (3)}	—	—
~	B	—	—
⋮ or ~	—	ES ⁽⁴⁾	FU ⁽⁵⁾

(2) Voltage code to be used for a starter-controller with communication module.

(3) d.c. voltage with maximum ripple of ±10 %.

(4) ⋮: 48...72 V, ~: 48 V.

(5) ⋮: 110...220 V, ~: 110...240 V.

Control unit and associated power base selection						
Functions provided	Maximum motor power ratings 50/60 Hz			Power base reference	Control unit reference	Line current
	< 400/415 V	500 V	690 V			
	KW	KW	KW			
■ Short-circuit protection	0.09	–	–	LUB12 or LUB32	LUCLX6●●	0.15...0.6
■ Manual reset	0.25	–	–	LUB12 or LUB32	LUCL1X●●	0.35...1.4
	1.5	2.2	3	LUB12 or LUB32	LUCL05●●	1.25...5
	5.5	5.5	9	LUB12 or LUB32	LUCL12●●	3...12
	7.5	9	15	LUB32	LUCL18●●	4.5...18
	15	15	18.5	LUB32	LUCL32●●	8...32

Operating characteristics						
Control units	Standard		Advanced			Multifunction
	LUCA	LUCB	LUCB	LUCB	LUCD	LUCM
Thermal overload protection	Integrated function					
Over current protection	14.2 x the setting current					3 to 17 x the setting current
Short-circuit protection	13 x I _r max (max current setting)					
Protection against phase loss	Integrated function					
Protection against phase imbalance	Integrated function					
Earth fault protection (equipment protection only)	Integrated function					
Tripping class	10	10	10	20		5...30
Motor type	3-phase		Single-phase	3-phase	Single-phase and 3-phase	
Thermal overload test function	Integrated function					
Overtorque	Integrated function					
No-load running	Integrated function					
Long starting time	Integrated function					
Reset method	Manual	Integrated function				Parameters can be set
	Automatic or remote	Function provided with accessory				Parameters can be set
		With function module, or parameters can be set via the bus with a communication module (see page 24614/2).				Parameters can be set via the bus with a communication module (see page 24614/2).

 Integrated function

 Function provided with accessory

Compatibility			
Compatibility of control unit LUCL●● with	References	Functions	
The controller	No	LUTM	Controller (without thermal overload protection)
Add-on contact blocks with fault signalling and auxiliary contacts	Yes	LUA1C11 LUA1C20 LUFN20 LUFN11 LUFN02	Add-on contact blocks with fault signalling (1 N/O + 1 N/C) Add-on contact blocks with fault signalling (2 N/O) Auxiliary contacts (2 N/O) Auxiliary contacts (1 N/O + 1 N/C) Auxiliary contacts (2 N/C)
Communication modules	Yes	ASILUFC5 and ASILUFC51 LUF00 LULC07 LULC08 LULC09 LULC15 LULC033	AS-Interface communication modules Parallel wiring module Profibus DP communication module (1 output/2 inputs) CANopen communication module (1 output/2 inputs) DeviceNet communication module (1 output/2 inputs) Advantys STB communication module (1 output/2 inputs) Modbus communication module (1 output/2 inputs)
Function modules	No	LUFW10 LUFDH11 LUFDA01 LUFDA10 LUFV2	Alarm function module Thermal overload signalling module with manual reset Thermal overload signalling module with automatic or remote reset (1 N/C) Thermal overload signalling module with automatic or remote reset (1 N/O) Motor load indication module

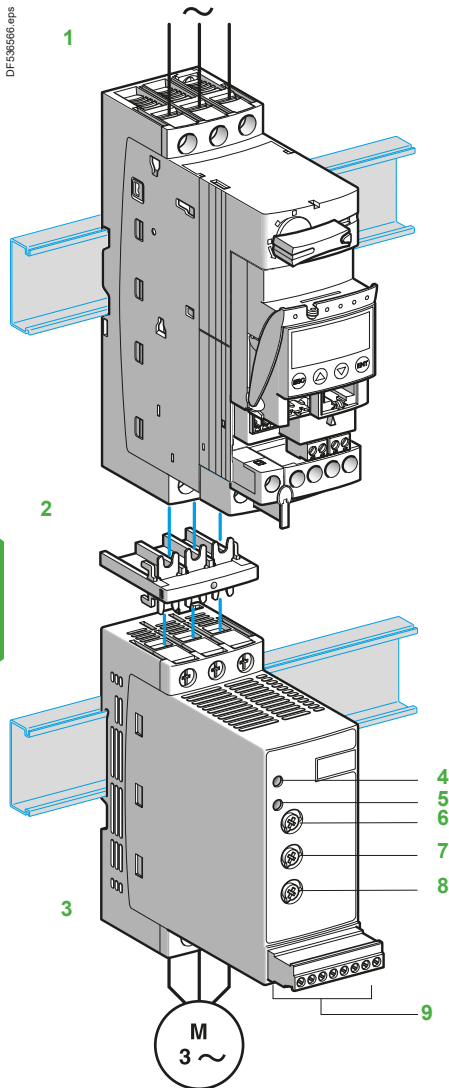

Introduction

The Altistart U01 is a soft start/soft stop unit for asynchronous motors. It is designed primarily for combinations with TeSys U controller-starters.

When combined with a TeSys U 1 controller by means of a connector 2, the Altistart U01 3 is a power option which provides the "Soft start/soft stop" function. The result is a unique, innovative motor starter.

Using the Altistart U01 starter enhances the starting performance of asynchronous motors by allowing them to start gradually, smoothly and in a controlled manner. It prevents mechanical shocks, which lead to wear and tear, and limits the amount of maintenance work and production downtime.

The Altistart U01 limits the starting torque and current peaks on starting, on machines which do not require a high starting torque.

The Altistart U01 is designed for the following simple applications:

- Conveyors
- Conveyor belts
- Pumps
- Fans
- Compressors
- Automatic doors and gates
- Small cranes
- Belt-driven machines, etc.

The Altistart U01 is compact and easy to install. It complies with standards IEC/EN 60947-4-2, carries UL, CSA, C-Tick, CCC certifications and CE marking.

■ ATSU01N2●●LT soft start/soft stop units

- Control two phases of the motor power supply to limit the starting current and for deceleration
- Internal bypass relay
- Motor power ratings ranging from 0.75 kW to 15 kW
- Motor supply voltages ranging from 200 V to 480 V, 50/60 Hz.

An external power supply is required for controlling the starter.

Description

- Altistart U01 soft start/soft stop units are equipped with:
 - A potentiometer for setting the starting time 6
 - A potentiometer for setting the deceleration time 8
 - A potentiometer for adjusting the start voltage threshold according to the motor load 7
 - 1 green LED 4 to indicate that the unit is switched on
 - 1 yellow LED 5 to indicate that the motor is powered at nominal voltage, if it is connected to the starter
 - A connector 9:
 - 2 logic inputs for Run/Stop commands
 - 1 logic input for the BOOST function
 - 1 logic output to indicate the end of starting
 - 1 relay output to indicate the starter has a power supply fault or the motor has reached a standstill at the end of the deceleration stage

ATSU01N2●●●LT soft start unit functions

■ 2-wire control

The run and stop commands are controlled by a single logic input. State 1 of logic input LI2 controls starting and state 0 controls stopping.

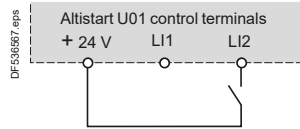

Wiring diagram for 2-wire control

■ 3-wire control

The run and stop commands are controlled by 2 different logic inputs.

Stopping is achieved when logic input LI1 opens (state 0).

The pulse on input LI2 is stored until input LI1 opens.

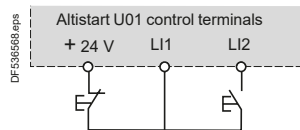

Wiring diagram for 3-wire control

■ Starting time

Controlling the starting time means that the time of the voltage ramp applied to the motor can be adjusted to obtain a gradual starting time, dependent on the motor load.

■ Voltage boost function via logic input

Activating the BOOST logic input enables the function for supplying a starting overtorque capable of overcoming any mechanical friction.

When the input is at state 1, the function is active (input connected to the + 24 V) and the starter applies a fixed voltage to the motor for a limited time before starting.

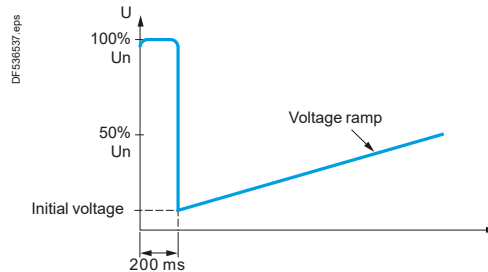

Application of a voltage boost equal to 100% of the nominal motor voltage

■ End of starting

○ application function for logic output LO1

ATSU01N2●●●LT soft start/soft stop units are equipped with an open collector logic output LO, which indicates the end of starting when the motor has reached nominal speed.

TeSys

Altistart U01 soft starter

Product references

109690SE.eps



ATSU01N222LT

TeSys U

DF538570.eps

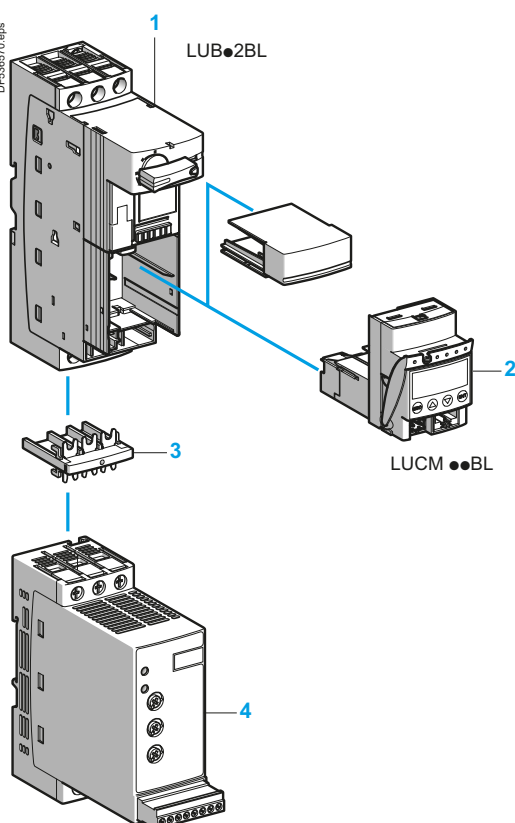

ATSU 01N2●●LT

Soft start/soft stop units for 0.75 to 15 kW motors (can be combined with the TeSys U starter)

Motor				Starter	
Motor power ⁽¹⁾				Nominal current	Reference
230 V		400 V	460 V	A	
kW	HP	kW	HP		
3-phase supply voltage: 200...480 V 50/60 Hz					
0.75	1	1.5	2	6	ATSU01N206LT
1.1	1.5	2.2	3		
1.5	2	–	5	9	ATSU01N209LT
–	–	4	–		
2.2	3	5.5	7.5	12	ATSU01N212LT
3	–	–	–		
4	5	7.5	10	22	ATSU01N222LT
5.5	7.5	11	15		
7.5	10	15	20	32	ATSU01N232LT

Accessories

Description	Used for starter	Reference
Power connector between ATSU01N2●●LT and TeSys U	ATSU01N2●●LT	VW3G4104

TeSys U starter and soft start unit combinations

Numerous possibilities for combinations and options are offered. Please consult the "TeSys U Starters-open version" specialist catalogue.

Motor power	Soft starter			TeSys U	
	230 V	400 V	460 V	Power base	Control unit ⁽²⁾
Voltage	kW/HP	kW	HP		
0.75/1	1.5	2		ATSU01N206LT	LUB12 LUC●05BL
1.1/1.5	2.2/3	3		ATSU01N206LT	LUB12 LUC●12BL
1.5/2	–	–		ATSU01N209LT	LUB12 LUC●12BL
–	4	5		ATSU01N209LT	LUB12 LUC●12BL
2.2/3	–	–		ATSU01N212LT	LUB12 LUC●12BL
3/–	5.5	7.5		ATSU01N212LT	LUB32 LUC●18BL
4/5	7.5	10		ATSU01N222LT	LUB32 LUC●18BL
5.5/7.5	11	15		ATSU01N222LT	LUB32 LUC●32BL
7.5/10	15	20		ATSU01N232LT	LUB32 LUC●32BL

Example of a starter-motor combination with:

- 1 non-reversing power base for DOL starting (LUB●2BL)
- 2 control unit (LUCM●●BL)
- 3 power connector (VW3G4104)
- 4 Altistart U01 soft start/soft stop unit (ATSU01N2●●LT)

⁽¹⁾ Standard motor power ratings, HP power ratings indicated according to standard UL508.
⁽²⁾ Depending on the configuration of the chosen TeSys U starter, replace the ● with A for standard, B for expandable, and M for multifunction.

TeSys

TeSys U All-in-one motor starters -

Coordination with soft starters / Variable speed controllers

Product references

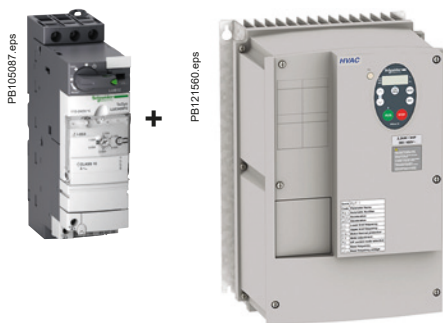

Coordination

The standard defines tests at different levels of current; the purpose of these tests is to place the equipment in extreme conditions.

The standard defines 2 types of coordination, according to the condition of the components after testing: type 1 and type 2.

Type 1 coordination requires that in a short-circuit condition, the contactor or starter must not present any danger to personnel or installations and must not be able to resume operation without repair or the replacement of parts.

The product combinations given below provide type 1 coordination

Soft start-soft stop unit/TeSys U starter controller combination with magnetic protection

TeSys U / Altistart 48: type 1 coordination

Power 400 V (kW)	TeSys U references (protection + power switching)	Soft start unit reference	
		Class 10	Class 20
5.5	LUB32 + LUCL32 or LUCL18	–	ATS48D17
7.5	LUB32 + LUCL32	ATS48D17	ATS48D22
11	LUB32 + LUCL32	ATS48D22	ATS48D32
15	LUB32 + LUCL32	ATS48D32	ATS48D38

Variable speed controller/TeSys U starter controller combination with magnetic protection

TeSys U / Altivar 21 UL Type 1/IP 20: type 1 coordination

Power 400 V (kW)	TeSys U references (protection + power switching)	Variable speed controller reference
0.75	LUB12 + LUCL05	ATV21H075N4
		ATV21HU15N4
2.2	LUB12 + LUCL12	ATV21HU22N4
3	LUB12 + LUCL12	ATV21HU30N4
4	LUB12 + LUCL12	ATV21HU40N4
5.5	LUB32 + LUCL32 or LUCL18	ATV21HU55N4
7.5	LUB32 + LUCL32 or LUCL18	ATV21HU75N4
11	LUB32 + LUCL32	ATV21HD11N4
15	LUB32 + LUCL32	ATV21HD15N4

TeSys U / Altivar 21 IP 54: type 1 coordination

Power 400 V (kW)	TeSys U references (protection + power switching)	Variable speed controller reference
0.75	LUB12 + LUCL05	ATV21W075N4/N4C
1.5	LUB12 + LUCL12 or LUCL05	ATV21WU15N4/N4C
2.2	LUB12 + LUCL12	ATV21WU22N4/N4C
3	LUB12 + LUCL12	ATV21WU30N4/N4C
4	LUB12 + LUCL12	ATV21WU40N4/N4C
5.5	LUB32 + LUCL32 or LUCL18	ATV21WU55N4/N4C
7.5	LUB32 + LUCL32 or LUCL18	ATV21WU75N4/N4C
11	LUB32 + LUCL32	ATV21WD11N4/N4C
15	LUB32 + LUCL32	ATV21WD15N4/N4C

TeSys

TeSys U All-in-one motor starters -

Coordination with Soft starters / Variable speed controllers

Products coordination



Variable speed controller/TeSys U starter controller combination with magnetic protection (continued)

TeSys U / Altivar 31: type 1 coordination

Power 400 V (kW)	TeSys U references (protection + power switching)	Variable speed controller reference
0.37	LUB12 + LUCL05	ATV31H037N4
0.55	LUB12 + LUCL05	ATV31H055N4
0.75	LUB12 + LUCL05	ATV31H075N4
1.1	LUB12 + LUCL12	ATV31HU11N4
1.5	LUB12 + LUCL12	ATV31HU15N4
2.2	LUB12 + LUCL12	ATV31HU22N4
3	LUB32 + LUCL18	ATV31HU30N4
4	LUB32 + LUCL18	ATV31HU40N4
5.5	LUB32 + LUCL32	ATV31HU55N4
7.5	LUB32 + LUCL32	ATV31HU75N4

TeSys U / Altivar 61: type 1 coordination

Power 400V (kW)	TeSys U references (protection + power switching)	Variable speed controller reference
0.75	LUB12 + LUCL05	ATV61H075N4
1.5	LUB12 + LUCL12	ATV61HU15N4
2.2	LUB12 + LUCL12	ATV61HU22N4
3	LUB32 + LUCL18	ATV61HU30N4
4	LUB32 + LUCL18	ATV61HU40N4
5.5	LUB32 + LUCL32	ATV61HU55N4
7.5	LUB32 + LUCL32	ATV61HU75N4

TeSys U / Altivar 71: type 1 coordination

Power 400V (kW)	TeSys U references (protection + power switching)	Variable speed controller reference
0.75	LUB12 + LUCL05	ATV71H075N4
1.5	LUB12 + LUCL12	ATV71HU15N4
2.2	LUB12 + LUCL12	ATV71HU22N4
3	LUB32 + LUCL18	ATV71HU30N4
4	LUB32 + LUCL18	ATV71HU40N4
5.5	LUB32 + LUCL32	ATV71HU55N4

TeSys U

Technical Data for Designers

Contents

Characteristics.....	A4/42 to A4/53
Curves	A4/54 to A4/59
Dimensions	A4/60 to A4/61
Schemes.....	A4/62 to A4/74
Altistart U01 Soft starter	A4/75 to A4/81

TeSys

TeSys U All-in-one motor starters

Characteristics

Environment

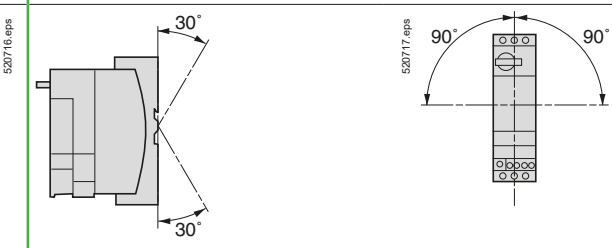
Product certifications			UL, CSA, CCC, GOST, ASEFA. ABS, BV, DNV, GL, LROS. ATEX.
Conforming to standards			IEC/EN 60947-6-2, CSA-22.2 N° 60947-4-1-14 UL 60947-4-1: with phase barrier LU9 SP0
Rated insulation voltage (Ui)	Conforming to IEC/EN 60947-1, overvoltage category III, degree of pollution: 3	V	690
	Conforming to UL508, CSA C22-2 n°14	V	600
Rated impulse withstand voltage (Uimp)	Conforming to IEC/EN 60947-6-2	kV	6
Degree of protection Conforming to IEC/EN 60947-1 (protection against direct finger contact)	Front panel outside connection zone		IP 40
	Front panel and wired terminals		IP 20
	Other faces		IP 20
Protective treatment	Conforming to IEC/EN 60068		"TH"
	Conforming to IEC/EN 60068-2-30	Cycles	12
	Conforming to IEC/EN 60068-2-11	h	48
Ambient air temperature around the device	Storage	°C	-40...+85
	Operation	°C	Power bases and standard and advanced control units: -25... +70. (At temperatures above 60 °C and up to 70 °C, for starter-controller LUB32, LUB38, leave a minimum gap of 9 mm between products). Power bases and multifunction control units: -25...+60. (At temperatures above 45 °C, leave a minimum gap of 9 mm between products. At temperatures above 55 °C and up to 60 °C, leave a gap of 20 mm between products.)
Maximum operating altitude		m	2000
Operating positions	In relation to normal vertical mounting plane		
Flame resistance	Conforming to UL 94		V2
	Conforming to IEC/EN 60695-2-12	°C	960 (parts supporting live components) °C 650
Environmental restrictions			Cadmium and silicone-free, recyclable
Shock resistance 1/2 sine wave = 11 ms	Conforming to IEC/EN 60068-2-27 ⁽¹⁾		Power poles open: 10 gn Power poles closed: 15 gn
Vibration resistance 5...300 Hz	Conforming to IEC/EN 60068-2-6 ⁽¹⁾		Power poles open: 2 gn Power poles closed: 4 gn ⁽²⁾
Resistance to electrostatic discharge	Conforming to IEC/EN 61000-4-2	kV	In open air: 8 - Level 3
		kV	On contact: 8 - Level 4
Immunity to radiated high-frequency disturbance	Conforming to IEC/EN 61000-4-3	V/m	10 - Level 3
Immunity to fast transient currents	Conforming to IEC/EN 61000-4-4	kV	All circuits except for serial link: 4 - Level 4
		kV	Serial link: 2 - Level 3
Immunity to dissipated shock waves	Conforming to IEC/EN 60947-6-2 Uc ~ 24...240 V, Uc --- 48...220 V Uc = 24 V ---	kV	Common mode
			Serial mode
Immunity to conducted high-frequency disturbance	Conforming to IEC/EN 61000-4-6	V	10
Radiated emission and conducted	Conforming to CISPR 11 and EN 55011		Class A

(1) Without modifying the contact states, in the most unfavourable direction.
(2) 2 gn with Advantys STB or CANopen communication modules.

Power circuit connection characteristics

Connection to Ø4 mm screw clamp terminals

Power base, control unit or reverser block type			LUB12 + LUCA or LUCB or LUCC or LUCD	LUB32/LUB38 + LUCA or LUCB or LUCC or LUCD	LUB12 + LUCM	LUB32 + LUCM	LU2B LU2M LU6M
Flexible cable without cable end	1 conductor	mm ²	2.5...10	2.5...10	2.5...10	2.5...10	2.5...10
	2 conductors	mm ²	1.5...6	1.5...6	1.5...6	1.5...6	1.5...6
Flexible cable with cable end	1 conductor	mm ²	1...6	1...6	1...6	1...6	1...6
	2 conductors	mm ²	1...6	1...6	1...6	1...6	1...6
Solid cable without cable end	1 conductor	mm ²	1...10	1...10	1...10	1...10	1...10
	2 conductors	mm ²	1...6	1...6	1...6	1...6	1...6
Screwdriver			Philips n° 2 or flat screwdriver: Ø6 mm				
Tightening torque			N.m	1.9...2.5	1.9...2.5	1.9...2.5	1.9...2.5

Control circuit connection characteristics

Connection to Ø3 mm screw clamp terminals

Flexible cable without cable end	1 conductor	mm ²	0.75...1.5	0.75...1.5	0.75...1.5	0.75...1.5	0.75...1.5
	2 conductors	mm ²	0.75...1.5	0.75...1.5	0.75...1.5	0.75...1.5	0.75...1.5
Flexible cable with cable end	1 conductor	mm ²	0.34...1.5	0.34...1.5	0.34...1.5	0.34...1.5	0.34...1.5
	2 conductors	mm ²	0.34...1.5	0.34...1.5	0.34...1.5	0.34...1.5	0.34...1.5
Solid cable without cable end	1 conductor	mm ²	0.75...1.5	0.75...1.5	0.75...1.5	0.75...1.5	0.75...1.5
	2 conductors	mm ²	0.75...1.5	0.75...1.5	0.75...1.5	0.75...1.5	0.75...1.5
Screwdriver			Philips n° 1 or flat screwdriver: Ø5 mm				
Tightening torque			N.m	0.8...1.2	0.8...1.2	0.8...1.2	0.8...1.2

Control circuit characteristics

Rated voltage of control circuit	~ 50/60 Hz	V	24...240	24...240	–	–	–
	≡	V	24...220	24...220	24	24	–
Voltage limits	≡ 24 V ⁽¹⁾	V	20...27	20...27	20...28	20...28	–
	Operation	~ 24 V	V	20...26.5	20...26.5	–	–
Drop-out	~ or ≡ 48...72 V	V	~ 38.5...72, ≡ 38.5...93	–	–	–	
	~ 110...240 V	V	~ 88...264	~ 88...264	–	–	
	≡ 110...220 V	V	≡ 88...242	≡ 88...242	–	–	
	≡ 24 V	V	14.5	14.5	14.5	14.5	
	~ 24 V	V	14.5	14.5	–	–	
	~ or ≡ 48...72 V	V	29	29	–	–	
Typical consumption	≡ 24 V	mA	130	220	150	200	120
	I max while closing	~ 24 V	mA	140	220	–	2360
	~ or ≡ 48...72 V	mA	280	280	–	–	2300
	~ 110...240 V, ≡ 110...220 V	mA	280	280	–	–	1000
I rms sealed	≡ 24 V	mA	60	80	70	75	120
	~ 24 V	mA	70	90	–	–	⁽²⁾
	~ or ≡ 48...72 V	mA	35	45	–	–	⁽²⁾
	~ 110...240 V, ≡ 110...220 V	mA	35	25	–	–	⁽²⁾
Heat dissipation		W	2	3	1.7	1.8	–
Operating time	Closing	ms	24 V: 70; 48 V: 60; ≥ 72 V: 50		75	65	–
	Opening	ms	35	35	35	35	–
Resistance to micro-breaks		ms	3	3	3	3	–
Resistance to voltage dips	IEC/EN 61000-4-11		At least 70 % of U _c for 500 ms				–
Mechanical durability	In millions of operating cycles		15	15	15	15	–
Maximum operating rate	In operating cycles per hour		3600	3600	3600	3600	–

Main pole characteristics

Number of poles			3	3	3	3	–
Isolation conforming to IEC/EN 60947-1	Possible		Yes	Yes	Yes	Yes	–
	Padlocking		1 padlock with Ø6.9 mm shank				–
Rated thermal current		A	12	32/38	12	32	–
Rated operational current (U _e ≤ 440V)	To IEC/ EN 60947-6-2	Category AC-41	θ ≤ 70°C: 12 A		θ ≤ 70°C: 32/38 A	θ ≤ 55°C: 12 A	θ ≤ 55°C: 32 A
	Category AC-43		θ ≤ 70°C: 12 A		θ ≤ 70°C: 32/38 A	θ ≤ 55°C: 12 A	θ ≤ 55°C: 32 A
Rated operational voltage		V	690 ⁽³⁾	690 ⁽³⁾	690 ⁽³⁾	690 ⁽³⁾	–
Frequency limits	Of the operating current	Hz	40...60	40...60	40...60	40...60	–
Power dissipated in the power circuits	Operational current	A	3 6 9 12	18 25 32 38			–
	Power dissipated in all three poles	W	0.1 0.3 0.6 1.1	2.4 4.6 7.5 10.6			–
Rated breaking capacity on short-circuit		V	230	440	500	690	–
		kA	50	50 (25 for LUB38)	10	4	–
Total breaking time		ms	2	2			–
Thermal limit	With I _{sc} max on 440 V	kA ² s	90	120	90	120	–

⁽¹⁾ Voltage with maximum ripple of ±10 %.

⁽²⁾ No consumption sealed.

⁽³⁾ For 690 V, use phase barrier LU9SP0.

TeSys

TeSys U All-in-one motor starters

Characteristics

Specific characteristics of power bases LU2B and reverser blocks LU2M or LU6M

Duration of inrush phase	~ 50/60 Hz	ms	25
	---	ms	15
Maximum operating time	Without change of direction	ms	75
	With change of direction	ms	150

General characteristics of auxiliary contacts

Conventional thermal current (Ith)	For ambient temperature $\theta < 70\text{ }^{\circ}\text{C}$	A	5
Frequency of the operational current		Hz	Up to 400
Minimum switching capacity $\lambda = 10^{-8}$	U min	V	17
	I min	mA	5
Short-circuit protection	Conforming to IEC/EN 60947-5-1	A	gG fuse: 4
Short-time rating	Permissible for	1 s	A 30
		500 ms	A 40
		100 ms	A 50
Insulation resistance		mΩ	10
Non-overlap time	Guaranteed between N/C and N/O contacts	ms	2 (on energisation and on de-energisation)

Specific characteristics of auxiliary contacts built-into the power base

Linked contacts	Conforming to IEC/EN 60947-4-1		Each power base has 1 N/O contact and 1 N/C contact which are mechanically linked
Mirror contact	Conforming to IEC/EN 60947-1		The N/C contact fitted in each power base reliably represents the state of the power contacts (safety scheme)
Rated operational voltage (Ue)		V	Up to ~ 690; --- 250
Rated insulation voltage (Ui)	Conforming to IEC/EN 60947-5-1	V	690
	Conforming to UL, CSA	V	600

Specific characteristics of auxiliary contacts in modules LUFN, of auxiliary contacts LUA1 and of reverser blocks LU2M and LU6M

Rated operational voltage (Ue)		V	Up to ~ 250; --- 250
Rated insulation voltage (Ui)	Conforming to IEC/EN 60947-5-1	V	250
	Conforming to UL, CSA	V	250

Rated operational power of contacts

Conforming to IEC/EN 60947-5-1

a.c. supply, categories AC-14 and AC-15

Electrical durability (valid for up to 3600 operating cycles/hour) on an inductive load such as the coil of an electromagnet: making current ($\cos \varphi 0.7$) = 10 times the power broken ($\cos \varphi = 0.4$)

	V	24	48	115	230	400	440	690
1 million operating cycles	VA	60	120	280	560	960	1050	1440
3 million operating cycles	VA	16	32	80	160	280	300	420
10 million operating cycles	VA	4	8	20	40	70	80	100

d.c. supply, category DC-13

Electrical durability (valid for up to 1200 operating cycles/hour) on an inductive load such as the coil of an electromagnet, without economy resistor, the time constant increasing with the load.

	V	24	48	125	250
W		120	90	75	68
W		70	50	38	33
W		25	18	14	12

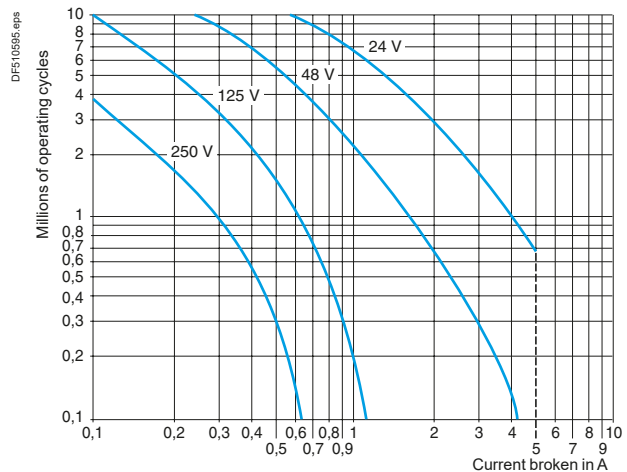
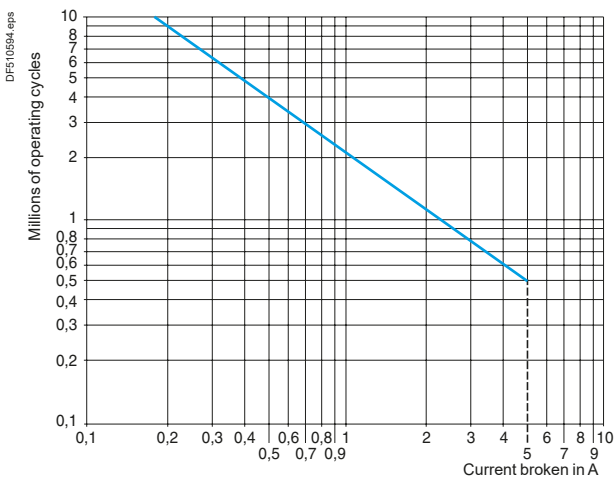

Characteristics of standard control units LUCA			
Protection	Motor type		3-phase
	Conforming to standard		IEC/EN 60947-6-2, UL 60947-4-1, CSA C22-2 n°14
Overload protection	Tripping class conforming to UL 508, IEC/EN 60947-6-2		10
	Frequency limits of the operational current	Hz	40...60
	Temperature compensation	°C	-25...+70
	Protection against phase imbalance		Yes
Short-circuit protection	Tripping threshold		13 x I _r max (max current setting)
	Tripping tolerance		±20 %

Characteristics of advanced control units LUCB, LUCC and LUCD				
Control unit type		LUCB	LUCC	LUCD
Protection	Motor type	3-phase	Single-phase	3-phase
	Conforming to standard	IEC/EN 60947-6-2, CSA C22-2 n°14	IEC/EN 60947-6-2, CSA C22-2 n°14	IEC/EN 60947-6-2, CSA C22-2 n°14
Overload protection	Tripping class conforming to UL 508, IEC/EN 60947-6-2	10	10	20
	Frequency limits of the operational current	Hz	40...60	40...60
	Temperature compensation	°C	-25...+70	-25...+70
	Protection against phase imbalance		Yes	Yes
Short-circuit protection	Tripping threshold	13 x I _r max.	13 x I _r max.	13 x I _r max.
	Tripping tolerance	±20 %	±20 %	±20 %

Characteristics of multifunction control units LUCM			
Protection	Motor type		Parameters can be set: single-phase or 3-phase
	Conforming to standard		IEC/EN 60947-6-2
Overload protection	Tripping class conforming to IEC/EN 60947-6-2		5, 10, 15, 20, 25, 30 (selectable)
	Frequency limits of the operational current	Hz	50...60
	Temperature compensation	°C	-25...+55
	Communication interface for terminal on enclosure door	Physical interface	
Communication interface for terminal on enclosure door	Connections		RJ45 on front panel
	Protocol		Modbus RTU
	Maximum transmission speed	bit/s	19 200 (self-configuration up to this value)
	Maximum return time	ms	200
Display	Type		LCD, 2 lines of 12 characters
	Language version		Multilanguage (English, French, German, Italian, Spanish)
	Precision		±5 %
	Resolution		1 % of I _r
Auxiliary supply	External type	V	~ 24, with maximum ripple of ±10 %.
	Heat dissipation	W	0.8

Configuration table for protection devices and alarms on multifunction control units LUCM								
	Tripping	Alarm	Adjustment of tripping threshold		Adjustment of time before tripping		Adjustment of alarm threshold	
	Factory setting	Factory setting	Range	Default value	Range	Default value	Range	Default value
Overcurrent	Activated ⁽¹⁾	–	3...17 I _r	14.2	–	–	–	–
Overload	Activated ⁽¹⁾	Activated	0.5...32 A ⁽²⁾	I _r min	Class: 5...30	5	10...100 % of the thermal state	85 %
Earth fault	Activated	Activated	0.2...5 I _r min	0.3 I _r min	0.1...1.2 s	0.1 s	0.2...5 I _r min	0.3 I _r min
Phase imbalance	Activated	Activated	10...30 %	10 %	0.2...20 s	5 s	10...30 %	10 %
Torque limitation	Deactivated	Deactivated	1...8 I _r	2 I _r	1...30 s	5 s	1...8 I _r	2 I _r
No-load running	Deactivated	Deactivated	0.3...1 I _r	0.5 I _r	1...200 s	10 s	0.3...1 I _r	0.5 I _r
Long starting time	Deactivated	Deactivated	1...8 I _r	I _r	1...200 s	10 s	1...8 I _r	I _r

Configuration of additional functions on multifunction control units LUCM		
	Factory setting	Setting range
Reset	Manual	Manual, automatic or remote
Time before reset	120 s	1...1000 s
Type of load	3-phase motor	3-phase motor, single-phase motor
	Self-cooled	Self-cooled, force cooled
Language	English	English, French, German, Italian, Spanish
Display	Average current	Average current, thermal state of motor, current in phase 1 / 2 / 3, earth leakage current, phase imbalance, cause of last 5 faults

⁽¹⁾ This function cannot be deactivated.

⁽²⁾ The setting range depends on the rating of the control unit used.

Characteristics of magnetic control unit LUCL

Protection	Motor type		3-phase
	Conforming to standard		When used in conjunction with an LUB12, LUB32 or LUB38 power base, magnetic control unit LUCL conforms to standard IEC 60947-6-2.
Short-circuit protection	Tripping threshold		14.2 x I _n (max. setting current)
	Tripping tolerance		±20 %
Environment			
Product certifications			CE
Conforming to standards			When used in conjunction an LUB power base, control unit LUCL conforms to standard 60947-6-2.
Rated insulation voltage (U _i)	Conforming to IEC/EN 60947-1, overvoltage category III, degree of pollution: 3	V	690
Rated impulse withstand voltage (U _{imp})	Conforming to IEC/EN 60947-6-2	kV	6
Safety separation of circuits SELV	Conforming to IEC/EN 60947-1 appendix N	V	Between the control or auxiliary circuit and the main circuit: 400 Between the control and auxiliary circuits: 40
Degree of protection (protection against direct finger contact)	Front panel outside connection zone		IP 40
	Front panel and wired terminals		IP 20
	Other faces		IP 20
Protective treatment	Conforming to IEC/EN 60068		"TH"
	Conforming to EN 60068-2-30	Cycles	12
	Conforming to IEC/EN 60068-2-11	h	48
Ambient air temperature around the device	Storage	°C	- 40...+ 85
	Operation	°C	Power bases and standard and advanced control units: - 25... + 70. (At temperatures above 60 °C and up to 70 °C, for I _e = 32 A, leave a minimum gap of 9 mm between products). Power bases and multifunction control units: - 25... + 60. (At temperatures above 45 °C, leave a minimum gap of 9 mm between products. At temperatures above 55 °C up to 60 °C, leave a gap of 20 mm between products.)
Maximum operating altitude		m	2000
Operating positions	In relation to normal vertical mounting plane		
Flame resistance	Conforming to UL 94		V2
	Conforming to IEC/EN 60695-2-12	°C	960 (parts supporting live components) °C 650
Environmental restrictions			Cadmium and silicone-free, recyclable
Shock resistance 1/2 sine wave = 11 ms	Conforming to IEC/EN 60068-2-27 ⁽¹⁾		Power poles open: 10 gn Power poles closed: 15 gn
			Power poles open: 2 gn Power poles closed: 4 gn ⁽²⁾
Vibration resistance 5...300 Hz	Conforming to IEC/EN 60068-2-6 ⁽¹⁾		Power poles open: 2 gn Power poles closed: 4 gn ⁽²⁾
			Power poles open: 2 gn Power poles closed: 4 gn ⁽²⁾
Resistance to electrostatic discharge	Conforming to IEC/EN 61000-4-2	kV	In open air: 8 - Level 3
		kV	On contact: 8 - Level 4
Immunity to radiated high-frequency disturbance	Conforming to IEC/EN 61000-4-3	V/m	10 - Level 3
Immunity to fast transient currents	Conforming to IEC/EN 61000-4-4	kV	All circuits except for serial link: 4 - Level 4
		kV	Serial link: 2 - Level 3
Immunity to dissipated shock waves	Conforming to IEC/EN 60947-6-2 U _c ~ 24...240 V, U _c ~ 48...220 V U _c = 24 V ~		Common mode
		kV	2
			Serial mode 1
			Not applicable
Immunity to conducted high-frequency disturbance	Conforming to IEC/EN 61000-4-6	V	10

(1) Without modifying the contact states, in the most unfavourable direction.
(2) 2 gn with Advantys STB or CANopen communication modules.

Power circuit connection characteristics of LUCL										
Power base and control unit type		LUB12 + LUCL		LUB32 + LUCL		LUB38 + LUCL				
Connection to Ø4 mm screw clamp terminals										
Flexible cable without cable end	1 conductor	mm ²	2.5...10		2.5...10					
	2 conductors	mm ²	1.5...6		1.5...6					
Flexible cable with cable end	1 conductor	mm ²	1...6		1...6					
	2 conductors	mm ²	1...6		1...6					
Flexible cable without cable end	1 conductor	mm ²	1...10		1...10					
	2 conductors	mm ²	1...6		1...6					
Screwdriver			Philips n° 2 or flat screwdriver: Ø6 mm							
Tightening torque		N.m	1.9...2.5		1.9...2.5					
Control circuit connection characteristics of LUCL										
Connection to Ø3 mm screw clamp terminals										
Flexible cable without cable end	1 conductor	mm ²	0.75...1.5		0.75...1.5					
	2 conductors	mm ²	0.75...1.5		0.75...1.5					
Flexible cable with cable end	1 conductor	mm ²	0.34...1.5		0.34...1.5					
	2 conductors	mm ²	0.34...1.5		0.34...1.5					
Flexible cable without cable end	1 conductor	mm ²	0.75...1.5		0.75...1.5					
	2 conductors	mm ²	0.75...1.5		0.75...1.5					
Screwdriver			Philips n° 2 or flat screwdriver: Ø5 mm							
Tightening torque		N.m	0.8...1.2		0.8...1.2					
Control circuit characteristics of LUCL										
Rated control circuit voltage	~ 50/60 Hz	V	24...240		24...240					
	≡	V	24...220		24...220					
Voltage limits Operation	≡ 24 V ⁽¹⁾	V	20...27		20...27					
	~ or ≡ 48...72 V	V	~ 38.5...72, ≡ 38.5...93		~ 38.5...72, ≡ 38.5...93					
Drop-out	~ 110...240 V	V	~ 88...264		~ 88...264					
	≡ 110...240 V	V	≡ 88...242		≡ 88...242					
Typical consumption I max while closing	≡ 24 V	mA	130		220					
	~ 24 V	mA	140		220					
I rms sealed	~ or ≡ 48...72 V	mA	280		280					
	~ 110...240 V, ≡ 110...220 V	mA	280		280					
Heat dissipation	≡ 24 V	mA	60		80					
	~ 24 V	mA	70		90					
Operating time Closing	~ or ≡ 48...72 V	mA	35		45					
	~ 110...240 V, ≡ 110...220 V	mA	35		25					
Operating time Opening	≡ 24 V	W	2		3					
	Closing	ms	24 V: 70; 48 V: 60; ≥ 72 V: 50		24 V: 70; 48 V: 60; ≥ 72 V: 50					
Resistance to micro-breaks	Opening	ms	35		35					
		ms	3		3					
Resistance to voltage dips	IEC/EN 61000-4-11		At least 70 % of U _c for 500 ms							
Mechanical durability	In millions of operating cycles		15		15					
Maximum operating rate	In operating cycles per hour		3600		3600					
Main pole characteristics of LUCL										
Number of poles			3		3					
Isolation conforming to IEC/EN 60947-1	Possible		Yes		Yes					
	Padlocking		1 padlock with Ø6.9 mm shank		1 padlock with Ø6.9 mm shank					
Rated thermal current		A	12		32 (38 A for LUB38)					
Rated operational current (U _e ≤ 440 V)	Conforming to IEC/EN 60947-6-2	Category AC-41	θ ≤ 70 °C: 12 A		θ ≤ 70 °C: 32 A (38 A for LUB38)					
		Category AC-43	θ ≤ 70 °C: 12 A		θ ≤ 70 °C: 32 A		38			
Rated operational voltage		V	690 ⁽³⁾		690 ⁽³⁾		690			
Frequency limits Of the operating current		Hz	40...60		40...60		40...60			
Power dissipated in the power circuits	Operational current	A	3	6	9	12	18	25	32	38
	Power dissipated in all three poles	W	0.1	0.3	0.6	1.1	2.4	4.6	7.5	10.5
Rated breaking capacity on short-circuit		V	230	440	500	690				
		kA	50	50	10	4				
Total breaking time		ms	2	2	2					
Thermal limit With I _{sc} max on 440 V		kA ² s	90							120

(1) d.c. voltage with maximum ripple of ± 10 %.

(2) No consumption sealed.

(3) For 690 V, use phase barrier LU9SP0.

Characteristics of limiter-disconnector LUALB1

Rated insulation voltage (Ui) conforming to standard IEC/EN 60947-1	V	690
Conventional thermal current (Ith) conforming to standard IEC/EN 60947-1	A	32
Operating threshold I rms	kA	50
Breaking capacity	V	440 690
	kA	130 70
Mounting		Directly on the upstream terminals of the starter-controller
Cabling		
Solid cable	1 conductor	mm² 1.5...10
	2 conductors	mm² 1.5...6
Flexible cable without cable end	1 conductor	mm² 1...10
	2 conductors	mm² 1...6
Flexible cable with cable end	1 conductor	mm² 1...6
	2 conductors	mm² 1...6
Screwdriver		Phillips n°2 or flat screwdriver Ø6 mm
Tightening torque	N.m	1.9...2.5

Characteristics of current limiter LA9LB920

Rated insulation voltage (Ui) conforming to standard IEC/EN 60947-1	V	690
Conventional thermal current (Ith) conforming to standard IEC/EN 60947-1	A	63
Operating threshold I rms	A	1000
Breaking capacity	V	440 690
	kA	100 35
Mounting		Separate
Cabling		
Solid cable	1 conductor	mm² 1.5...25
	2 conductors	mm² 1.5...10
Flexible cable without cable end	1 conductor	mm² 1.5...25
	2 conductors	mm² 2.5...10
Flexible cable with cable end	1 conductor	mm² 1.5...16
	2 conductors	mm² 1.5...4
Screwdriver		Phillips n°2 or flat screwdriver Ø6 mm
Tightening torque	N.m	2.2

Characteristics of thermal overload alarm function modules LUFW10

Activation threshold		Fixed at 88 % of the thermal tripping state
Hysteresis between activation and switching off		5 %
Display		By LED on front panel
Supply		Powered by the control unit
Discrete output characteristics	Type	N/O contact
	AC-15	230 V max; 400 VA 100 000 operating cycles
	DC-13	24 V; 50 W 100 000 operating cycles
Conventional thermal current (Ith)	For ambient temperature $\theta < 70$ °C	A 2
Short-circuit protection	Conforming to IEC/EN 60947-5-1	A gG fuse: 2

Characteristics of thermal overload fault signalling and reset modules

Module type		LUFDH11	LUFDA01	LUFDA10
Fault signalling		By LED on front panel		
External power supply	V	~/- 24... 240		
Module consumption	mA	7 at ~ 24 1.1 at ~ 240		
Discrete outputs	Type	1 N/C+ 1 N/O	1 N/C	1 N/O
	AC-15	230 V max; 400 VA 100 000 operating cycles		
	DC-13	24 V; 50 W 100 000 operating cycles		
Conventional thermal current (Ith)	For ambient temperature $\theta < 70$ °C	A 2		
Short-circuit protection	Conforming to IEC/EN 60947-5-1	A gG fuse: 2		
Reset input	Conductor c.s.a.	mm² 0.2 min		
	Length	m 500 (R = 50 Ω , L = 52.8 mH, Cp = 93 pF)		



Characteristics of motor load indication function module LUFV2

Analogue output			4 - 20 mA
Signal delivered			Value of I average/I _r ratio within the range of 0 to 2 for LUCB and LUCD Value of I average/I _r ratio within the range of 0 to 3 for LUCD
Load impedance	Minimum	kΩ	–
	Maximum	Ω	500
	Typical	Ω	100
Signal characteristics with advanced control unit	Precision		±6 %
Signal characteristics with multifunction control unit	Precision		±10 %
	Resolution		1 % of I _r
Supply			External ~ 24 V

Characteristics of AS-Interface communication modules ASILUFC5 and ASILUFC51

Module type		ASILUF C5	ASILUF C51
Product certification		AS-Interface V2.1 n° 52901	AS-Interface V2.1 n° 52303
AS-Interface profile		7.D.F.0	7.A.7.E
Ambient air temperature		°C Operation -25...+70	
Cycle time		5 ms	10
Addressing		31 slaves	62 slaves
AS-Interface supply		V 29.5...31.5	
Current consumption	On the AS-Interface bus	mA	Normal operation: 25
		mA	Fault condition: 30
	On 24 V supply for the outputs	mA	200
Auxiliary supply		V ~ 24 ±30 %	
Number of outputs		2 dedicated to starter-controller coil operation	
Switching capacity of the solid state outputs		0.5 A/24 V (outputs protected against short-circuits)	
Indication/diagnostics		By 2 LEDs on front panel	

Characteristics of Modbus communication module LULC033

Physical interface			RS 485 multi-drop	
Connections			RJ45 on front panel	
Protocol			Modbus RTU	
Maximum transmission speed		bit/s	19 200 (self-configuration up to this value)	
Maximum return time		ms	30	
Addressing			By switches: from 0...31	
Ambient air temperature		°C	Operation -25...+55	
Discrete inputs	Number		2 (to be assigned according to the configuration)	
	Supply	V	~ 24	
	Input current	mA	7	
	Nominal input values	Voltage	V	~ 24 (positive logic)
		Current	mA	7
Response time	Change to state 1	ms	10 (±30 %)	
	Change to state 0	ms	10 (±30 %)	
Input type			Resistive	
Solid state outputs	Number		3, of which 2 dedicated to starter-controller coil operation	
	Supply	V	~ 24	
	Max. current	mA	500	
	Protection	gl fuse	A	1
Switching capacity			0.5 A/24 V	
Indication/diagnostics			By 3 LEDs on front panel	

Characteristics of CANopen, Profibus DP and DeviceNet communication modules

















































Communication module			Profibus DP LULC07	CANopen LULC08	DeviceNet LULC09	
Services	Conformity class		NA	S 20 (Schneider Electric)	NA	
	Standard		Profibus DP	CIADS-301 V4.02 DR 303-2	IEC 62026-1, overvoltage category III, degree of pollution: 3	
	Profile		LVSG V1.0 MS (Motor Starter) and MMS (Motor Management Starter)	–	ODVA (Open DeviceNet Vendor Association) MS (Motor Starter)	
	Protocol		Profibus DP	CAN 2.0A (2B passive)	CAN 2.0A (2B passive)	
	Address		1...125	0...127 (by switches)	0...63	
Structure	Physical interface		9-way SUB-D male	9-way SUB-D female	"Open Style" connector	
	Binary rate		9600 Kbits/s...12 Mbits/s	10, 20, 50, 125, 250, 500 and 1000 Kbits/s (by switches)	125...500 kbaud	
	Cables		2 shielded twisted pairs			
Supply for the discrete outputs and control	~ 24 V	V	20...28			
	Current consumption	A	1.5 (max)			
	Protection by gl fuse	A	2			
Ambient air temperature		°C	Operation -25...+55			
Logic inputs	Number		2 (to be assigned according to the configuration)			
	Supply		V	~ 24		
	Input current		mA	7		
	Nominal input values	Voltage		V	~ 24 (positive logic)	
		Current		mA	7	
	Response time	Change to state 1		ms	10 (±30 %)	
		Change to state 0		ms	10 (±30 %)	
Input type			Resistive			
Discrete outputs	Number		3, of which 2 dedicated to starter-controller coil operation			
	Max. current		mA	500		
	Short-circuit protection			Yes		
	Switching capacity			0.5 A / ~ 24 V		
Indication/diagnostics			By 3 LEDs on front panel			

Characteristics of Advantys STB communication module LULC15

Physical interface			CAN		
Connections			Fire Wire		
Protocol			CAN 2.0 and CAN 2.B (passive mode)		
Transmission speed		kbit/s	800		
Addressing			Self-addressing		
Supply for the discrete outputs and control	~ 24 V	V	20...28		
	Current consumption	A	1.5 (max)		
	Protection by gl fuse	A	2		
Ambient air temperature		°C	Operation -25...+55		
Discrete inputs	Number		2 (to be assigned according to configuration)		
	Supply		V	~ 24	
	Input current		mA	7	
	Nominal input values	Voltage		V	~ 24 (positive logic)
		Current		mA	7
	Response time	Change to state 1		ms	10 (± 30 %)
		Change to state 0		ms	10 (± 30 %)
Input type			Resistive		
Discrete outputs	Number		3, of which 2 dedicated to starter-controller coil operation		
	Max. current		mA	500	
	Short-circuit protection			Yes	
	Switching capacity			0.5 A / ~ 24 V	
Indication/diagnostics			By 3 LEDs on front panel		

Characteristics

Connection characteristics							
Module type		LUFW10, LUFDH11, LUFDA01 and LUFDA10	LUFV2	ASILUFC5 and ASILUFC51			
				Inputs and 24 V auxiliary supply	Outputs		
Connectors	Pitch		5.08	3.81	5.08	3.81	
Flexible cable without cable end	1 conductor	mm ²	0.2...1.5	0.14...1	0.2...1.5	0.14...1	
	2 identical conductors	mm ²	0.2...1	0.14...0.75	0.2...1	0.14...0.75	
Flexible cable with cable end	Without insulated ferrule	1 conductor	mm ²	0.25...1.5	0.25...1	0.25...1	
		2 identical conductors	mm ²	0.25...1	0.25...0.34	0.25...1	0.25...0.34
	With insulated ferrule	1 conductor	mm ²	0.25...1.5	0.25...0.5	0.25...1.5	0.25...0.5
		2 identical conductors (Use a double cable end)	mm ²	0.5...1	0.5	0.5...1	0.5
Solid cable without cable end	1 conductor	mm ²	0.2...1.5	0.14...1	0.2...1.5	0.14...1	
	2 identical conductors	mm ²	0.2...1	0.14...0.5	0.2...1	0.14...0.5	
Conductor size	1 conductor		AWG24... AWG16	AWG26... AWG16	AWG24... AWG16	AWG26... AWG16	
Tightening torque		N.m	0.5...0.6	0.20...0.25	0.5...0.6	0.20...0.25	
Flat screwdriver		mm	3.5	2.5	3.5	2.5	
Module type		LULC033, LULC08 and LULC15	LUFC00	LULC09			
				Inputs and 24 V auxiliary supply	Connection on the bus		
Connectors	Pitch		3.81	3.81	3.81	5 (Open Style) DeviceNet	
Flexible cable without cable end	1 conductor	mm ²	0.14...1	0.14...1	0.14...1	0.2...2.5	
	2 identical conductors	mm ²	0.14...0.75	0.14...0.75	0.14...0.75	0.5...1.5	
Flexible cable with cable end	Without insulated ferrule	1 conductor	mm ²	0.25...1	0.25...1	0.25...2.5	
		2 identical conductors	mm ²	0.25...0.34	0.25...0.34	0.25...1	
	With insulated ferrule	1 conductor	mm ²	0.25...0.5	0.25...0.5	0.25...0.5	0.25...2.5
		2 identical conductors (Use a double cable end)	mm ²	0.5	0.5	0.75	0.5...1.5
Solid cable without cable end	1 conductor	mm ²	0.14...1	0.14...1	0.14...1	0.2...2.5	
	2 identical conductors	mm ²	0.14...0.5	0.14...0.5	0.14...0.5	0.14...0.5	
Conductor size	1 conductor		AWG26... AWG16	AWG26... AWG16	AWG26... AWG16	AWG24... AWG16	
Tightening torque		N.m	0.20...0.25	0.20...0.25	0.20...0.25	0.5...0.6	
Flat screwdriver		mm	2.5	2.5	2.5	3.5	

Knob positions - Poles and Signaling contact states									
TeSys U operating status	Position of rotary knob	Indication on front panel	N/O pole contact	N/C pole contact	N/O contact any fault	N/C contact any fault	⊖ N/O contact product ready	N/C contact Rotary knob on OFF position	
References of add-on contact blocks and auxiliary contact modules Terminal referencing	–	–	–	LUFN11 31-32	LUA1C20 97-98	LUA1C11 95-96	LUA1C20 17-18	–	
	or	–	–	LUFN02 31-32 41-42	LUA1C200 No terminal block	LUA1C110 No terminal block	LUA1C200 No terminal block	LUA8E20 57/58 67/68	
	or	–	–	LUFN20 33-34 43-44	LUB9N11 21-22	–	LUA1C11 17-18	–	
	or	–	–	LUFN11 43-44	–	–	LUA1C110 No terminal block	–	
	or	–	–	LUB9N11 13-14	–	–	–	–	
Off		0							
Ready to operate		0							
Start		1							
Tripped on short-circuit		I>>							
Tripped on thermal overload	Manual reset mode		0						
	Automatic reset on thermal overload fault mode		0						
	Remote reset mode		0						

N/O contact  in closed position.

N/C contact  in open position.

Data profile under AS-Interface				Standard LUCA	Advanced LUCB, CC, CD	Multifunction LUCM
Control unit present in the product						
Status		D0	Ready (available)			
		D1	Poles closed (running)			
Commands		D0	Start - forward running			
		D1	Start - reverse running			

Main registers accessible with Modbus, CANopen, Advantys STB, Profibus DP and DeviceNet communication modules.						
For other registers and for further information, please consult the User's Manual <i>Communication variables</i> on the website www.schneider-electric.com						
Control unit present in the product				Standard	Advanced	Multifunction
Marking	Register 0...Register 99	Words...Bits	Commercial reference, serial number, software version			
Log	Register 100...Register 450	Words...Bits	Fault log, Operating log, Log of last 5 trips			
Status	Register 451...Register 464	Words...Bits	Alarm signalling (bits), Fault signalling (bits)			
Values	Register 465...Register 473	Words	Irms phase 1, phase 2, phase 3. Motor load, thermal status Earth leakage current. Phase imbalance and phase failure			
	Register 474...Register 599	Words...Bits	Reserved			
Configuration	Register 600...Register 699	Words...Bits	Protection and alarm thresholds, fallback mode and reset mode			
Commands	Register 700...Register 714	Words...Bits	Commands			

Status and values	Register 452	Bit 0	Short-circuit fault			
		Bit 1	Overcurrent fault			
		Bit 2	Thermal overload fault			
	Register 455	Bit 0	Ready (available)			
		Bit 1	Poles closed			
		Bit 2	Fault			
		Bit 3	Alarms			
		Bit 4	Tripped ("TRIP" position)			
		Bit 5	Fault acknowledgement allowed			
		Bit 6	Reserved			
		Bit 7	Motor running			
		Bit 8	Motor current % (bit 0)			
		Bit 9	Motor current % (bit 1)			
		Bit 10	Motor current % (bit 2)			
		Bit 11	Motor current % (bit 3)			
		Bit 12	Motor current % (bit 4)			
		Bit 13	Motor current % (bit 5)			
		Bit 14	Reserved			
	Bit 15	Motor starting				
Register 461	Bit 3	Thermal overload alarm				
Register 465	Word	Thermal status value				
Register 466	Word	Motor load value (Im/Ir)				

Configuration	Register 602	Bit 0	Manual reset on thermal overload fault			
		Bit 1	Remote reset on thermal overload fault			
		Bit 2	Automatic reset on thermal overload fault			
	Register 682	Value 0	Fallback mode validation			
		Value 1	Outputs OA1 and OA3 unchanged			
		Value 2	Outputs OA1 and OA3 forced to 0			
		Value 3	Outputs OA1 and OA3 unchanged, signalling existence of communication failure			
		Value 4	Outputs OA1 forced to 1 and OA3 unchanged			
Value 5	Outputs OA3 forced to 1 and OA1 unchanged					

Commands	Register 700	Bit 0	LO1 output command			
	Register 704	Bit 0	OA1 output command			
		Bit 1	OA3 output command			
		Bit 2	Reserved			
		Bit 3	Fault acknowledgement			
		Bit 4	Reserved			
		Bit 5	Trip test			
		Bit 6...15	Reserved			

 Data accessible

Tripping curves for control units LUCA, LUCB, LUCD

Average operating times at 20 °C according to multiples of the setting current, tolerance : $\pm 20\%$.

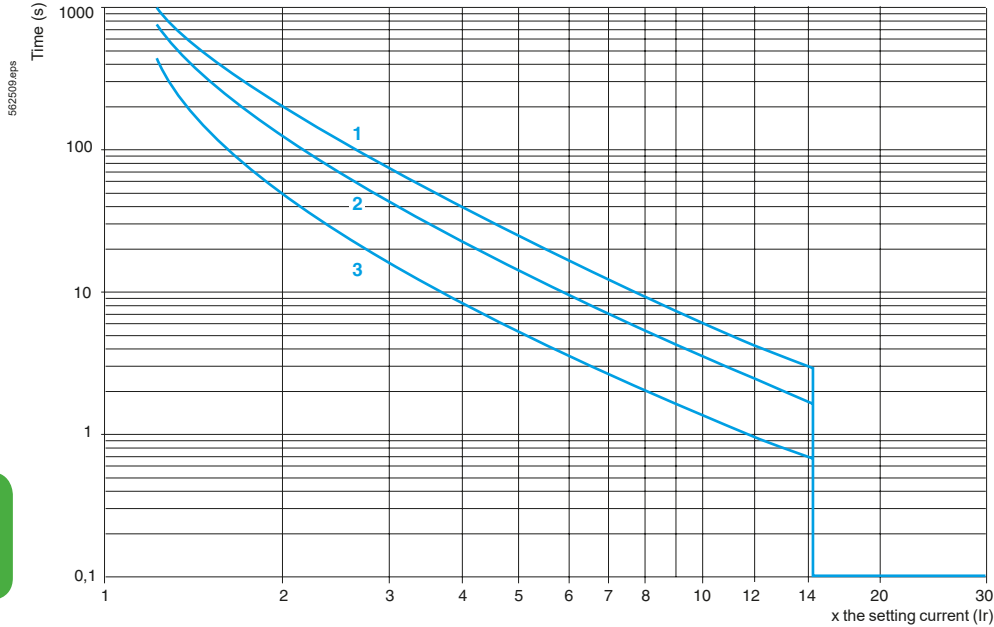

- Ref.
- 1 LUCD, 3 poles from cold state, class 20.
 - 2 LUCA, LUCB, 3 poles from cold state, class 10.
 - 3 LUCA, LUCB, LUCD, 3 poles from hot state.

Tripping curves for control units LUCC

Average operating times at 20 °C according to multiples of the setting current, tolerance : $\pm 20\%$.

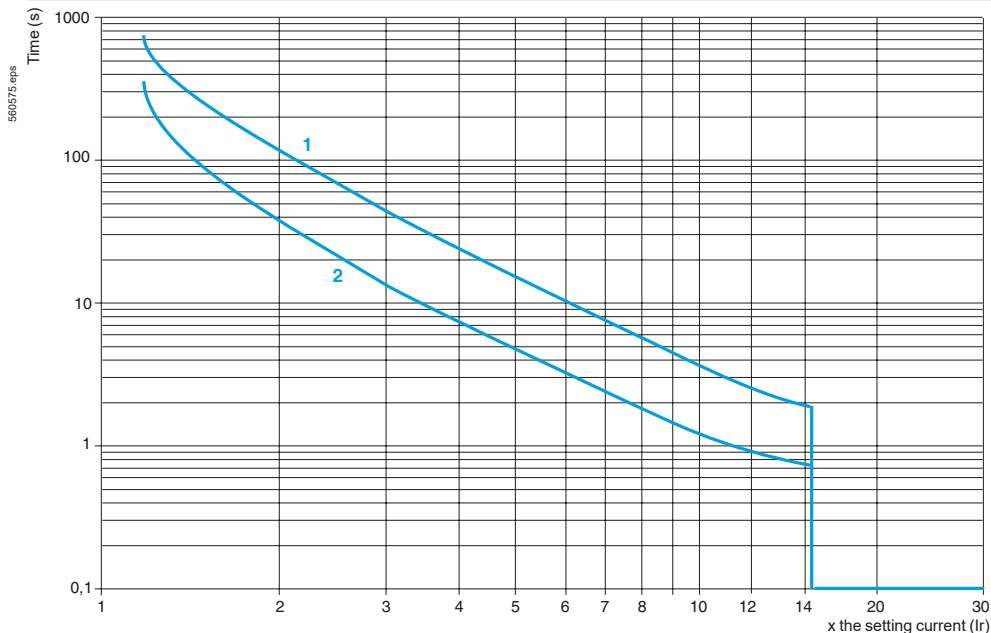

- 1 LUCC, single-phase, cold state.
- 2 LUCC, single-phase, hot state.

Tripping curves for control units LUCM

Cold state curves

Average operating times at 20 °C according to multiples of the setting current, tolerance : ± 20 %.

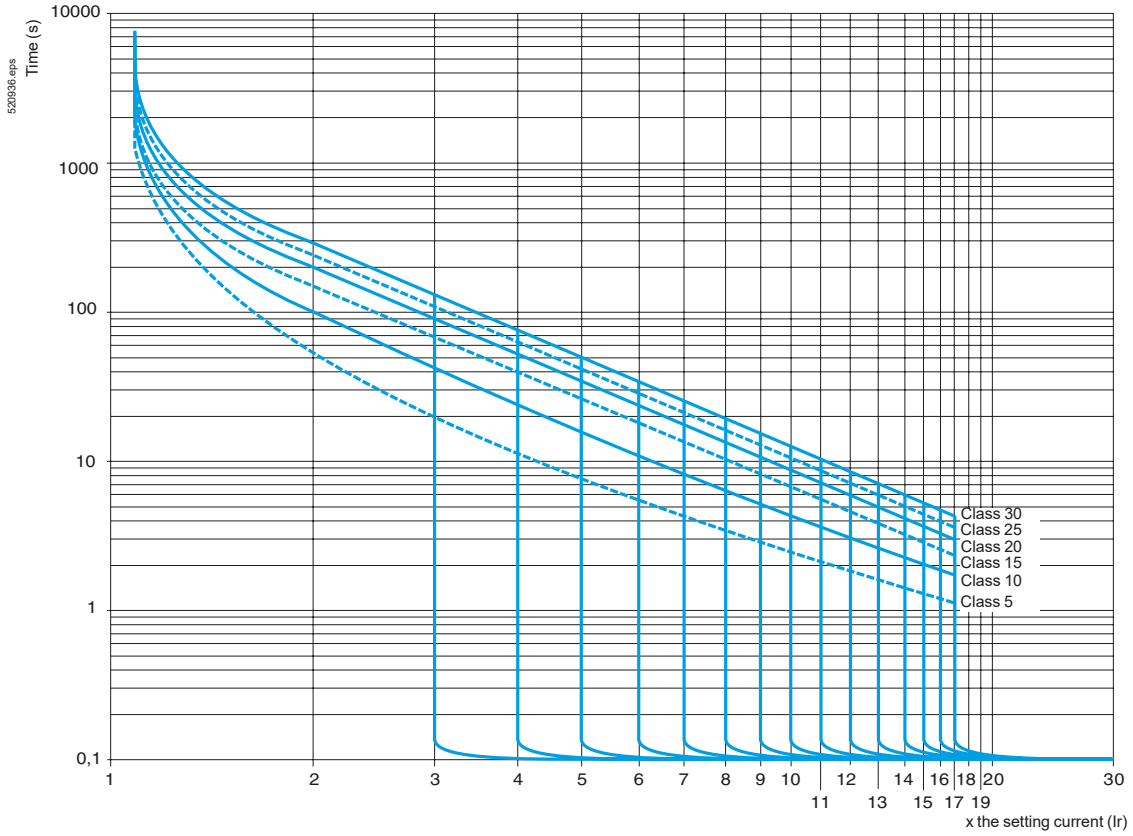

Tripping curves for control units LUCM

Hot state curves

Average operating times at 20 °C according to multiples of the setting current, tolerance : $\pm 20\%$

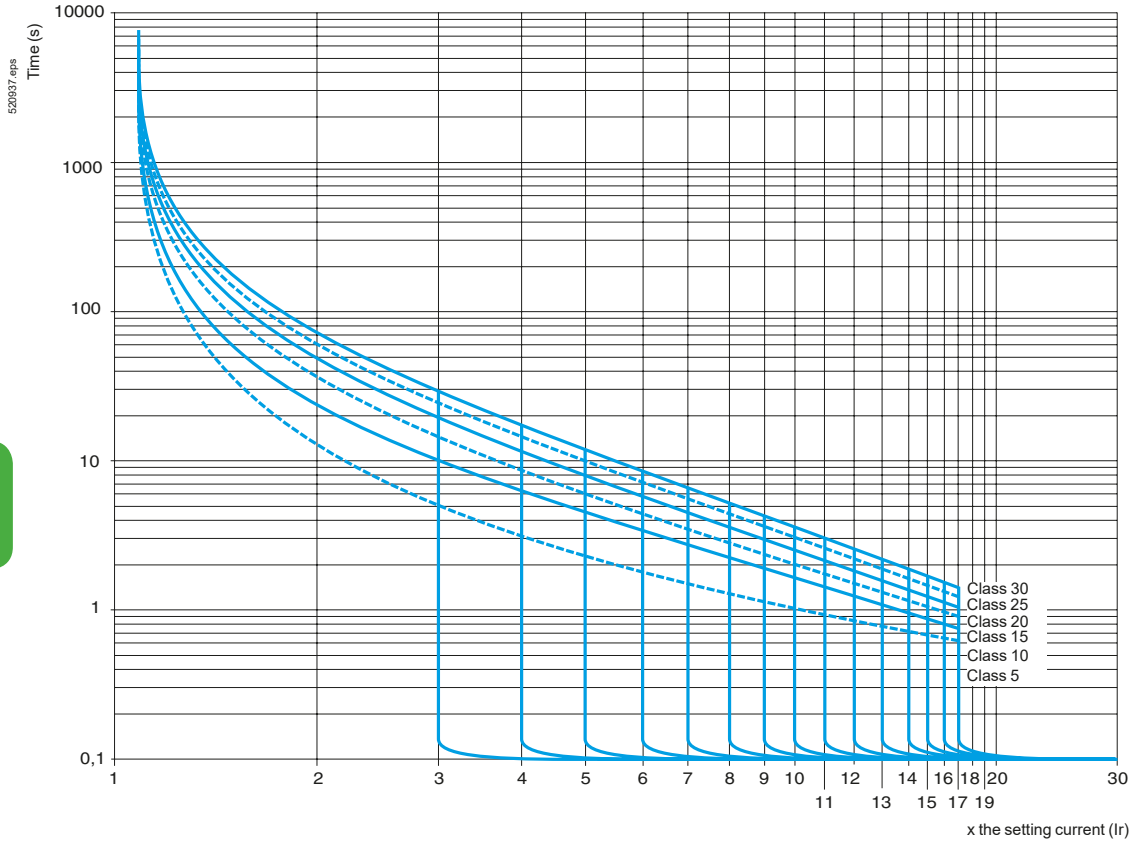

TeSys U

Ref.



Current limitation on short-circuit

$U_e = 460 \text{ V}$

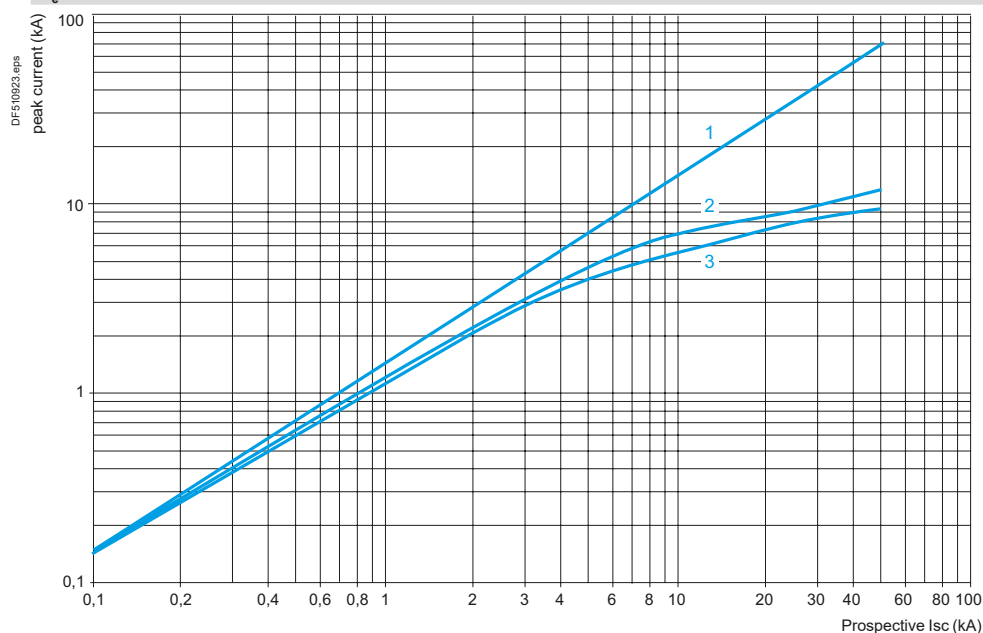

- 1 Maximum peak current
- 2 32 A, 38 A power base
- 3 12 A power base

Thermal limit on short-circuit

$U_e = 460 \text{ V}$

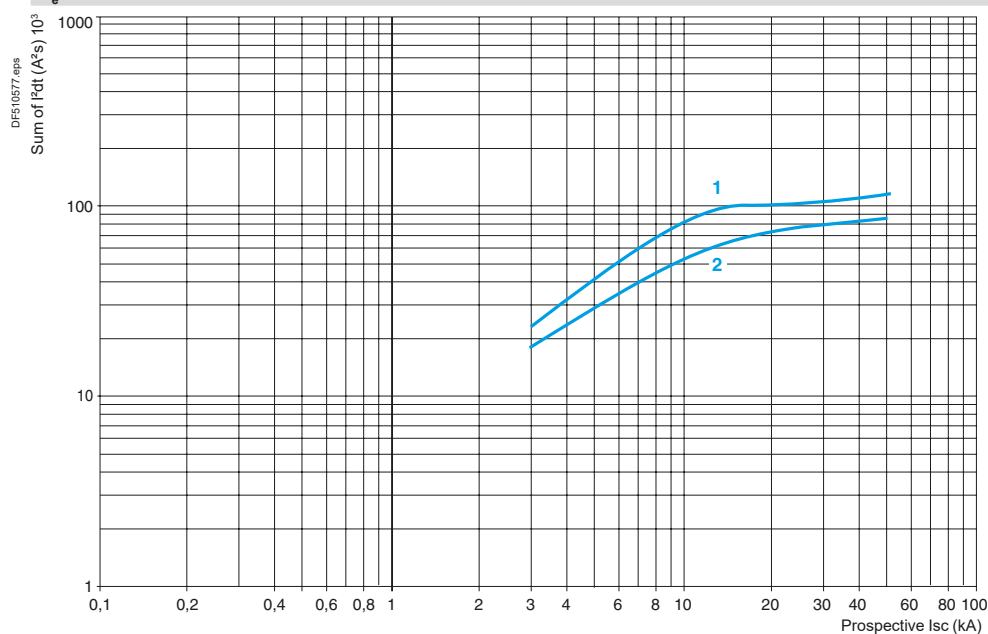

- 1 32 A, 38 A power base
- 2 12 A power base

TeSys

TeSys U All-in-one motor starters

Curves

Use in category AC-41

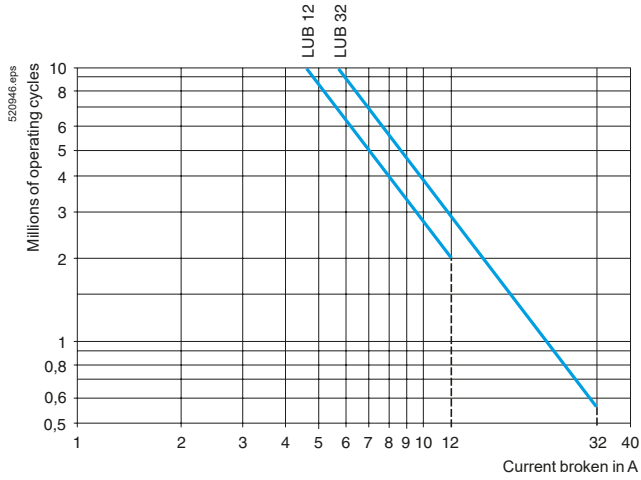

TeSys U

Use in category AC-43

U_e ≤ 440 V

U_e = 690 V

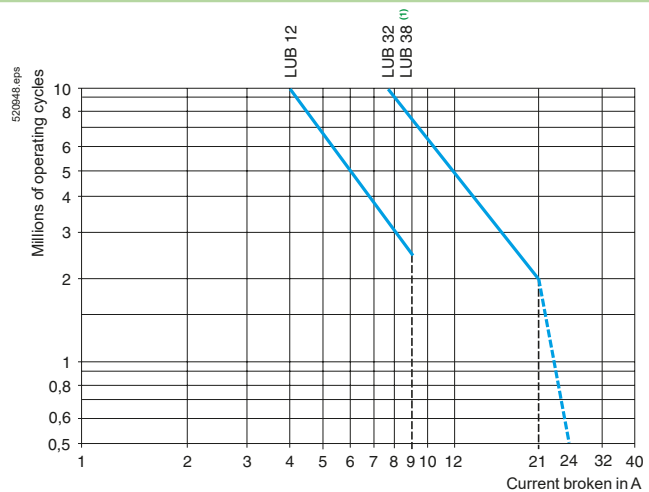
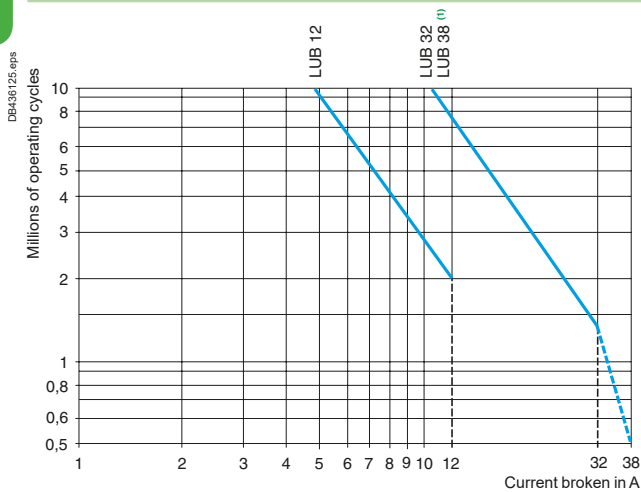

(1) Plain curve: LUB32 + LUB38, dotted curve: LUB38 only.

TeSys

TeSys U All-in-one motor starters

Curves

Use in category AC-44

Ue ≤ 440 V

Ue = 690 V

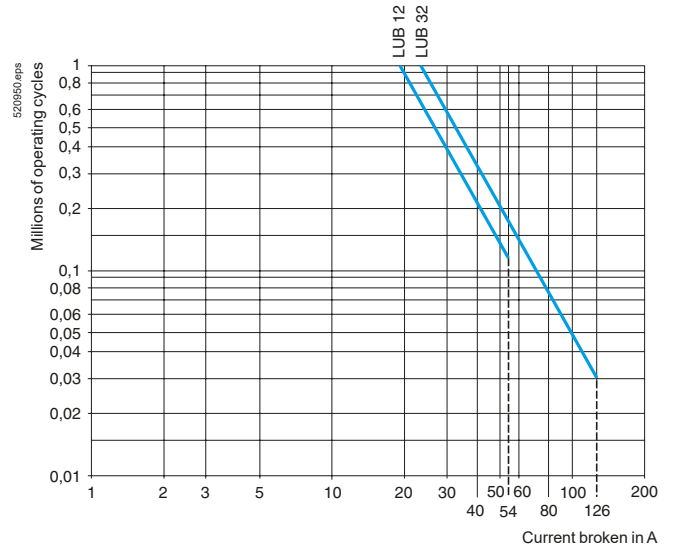
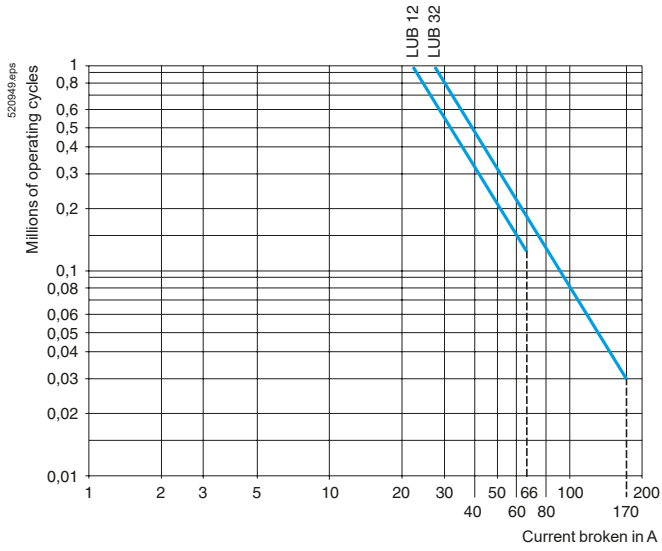

TeSys U

Ref.



TeSys

TeSys U All-in-one motor starters

Dimensions

Dimensions

Starter-controllers

LUB: non-reversing

LU2B: reversing

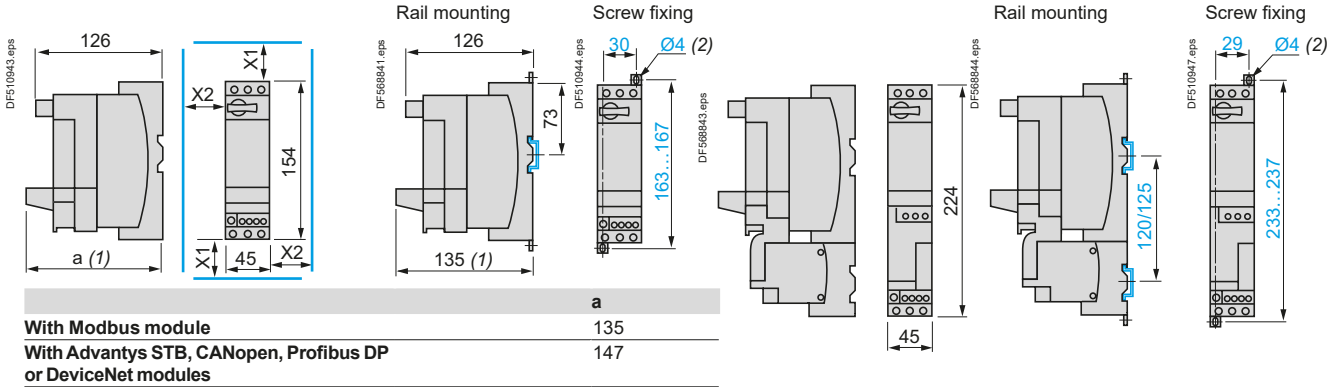

Minimum electrical clearance:
 X1 = 50 mm for Ue = 440 V and 70 mm for Ue = 500 and 690 V, X2 = 0

Reverser block for mounting separately from power base

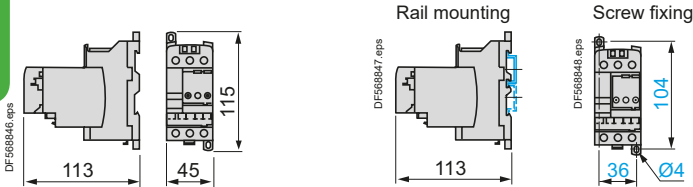

Sets of busbars and plug-in power sockets

GV2G445 and GV2G454

GV2G●●● with terminal block GV1G09

GV2G245 and G254

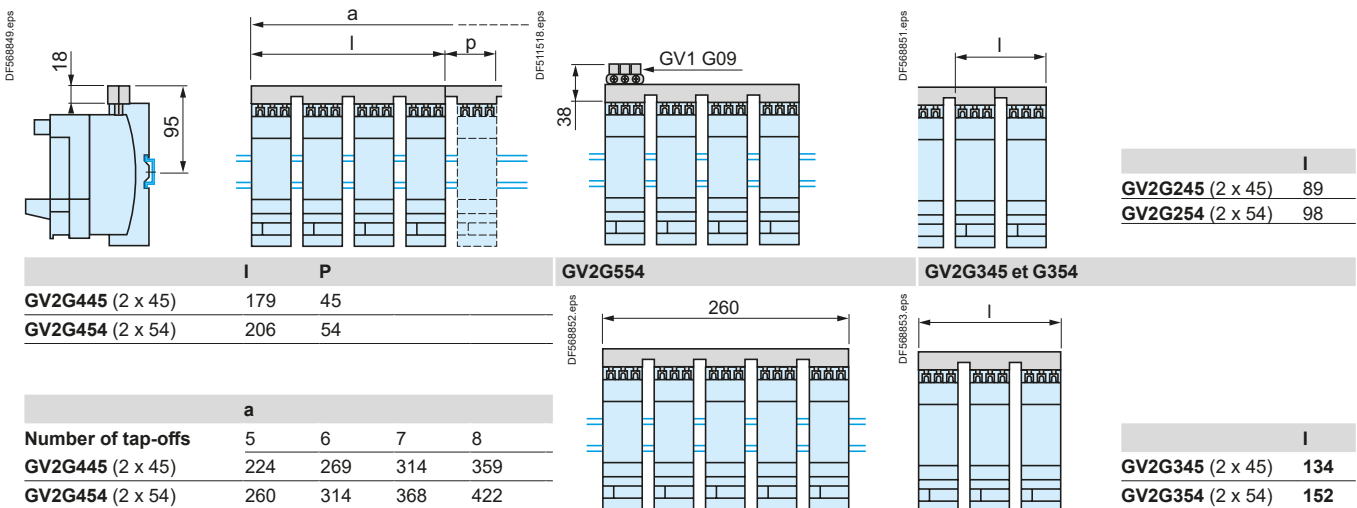

AK5JB144

AK5PC13, PC33, PC33L

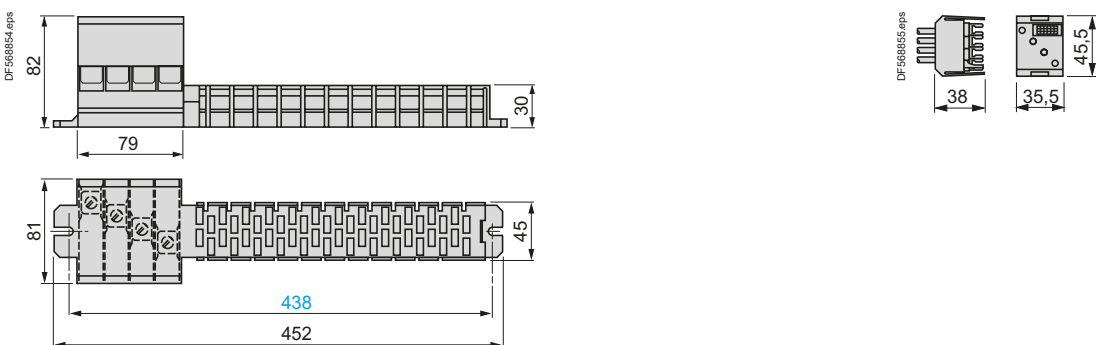

(1) Depth with communication module.
 (2) Retractable fixing lugs.

References: pages A4/10 and A4/11 Characteristics: page A4/42 Curves: pages A4/54 to A4/59 Schemes: pages A4/61 to A4/74

TeSys

TeSys U All-in-one motor starters

Dimensions

Dimensions, mounting

Limiter-disconnector LUALB1 Disconnector LUALB10

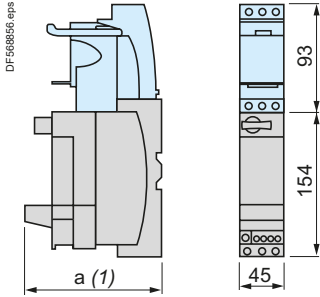

a	
With Modbus module	135
With Advantys STB, CANopen, Profibus DP or DeviceNet modules	147

Current limiter LA9LB920

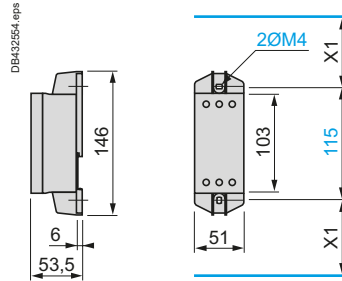

X1: Electrical clearance = 30 mm for $U_e \leq 690$ V

Door interlock mechanisms

LU9APN21, LU9APN22, LU9APN24

Door cut-out

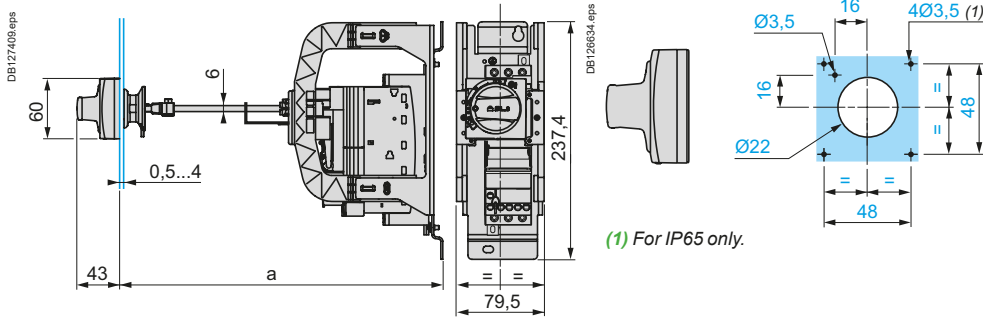

(1) For IP65 only.

	a	
	Mini	Maxi
LU9APN●●	191	300
LU9APN●● + GVAPK12	300	483

Addressing consoles

XZMC11

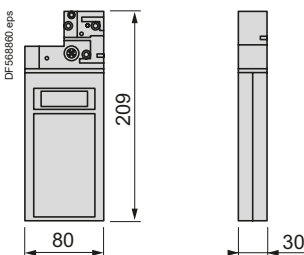

ASITERV2

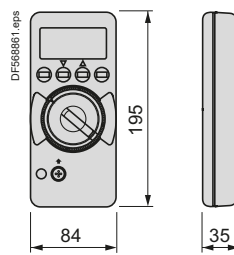

Splitter boxes

LU9GC3 (Modbus) LU9G02 and LU9G03

LU9GC7 (Profibus DP)

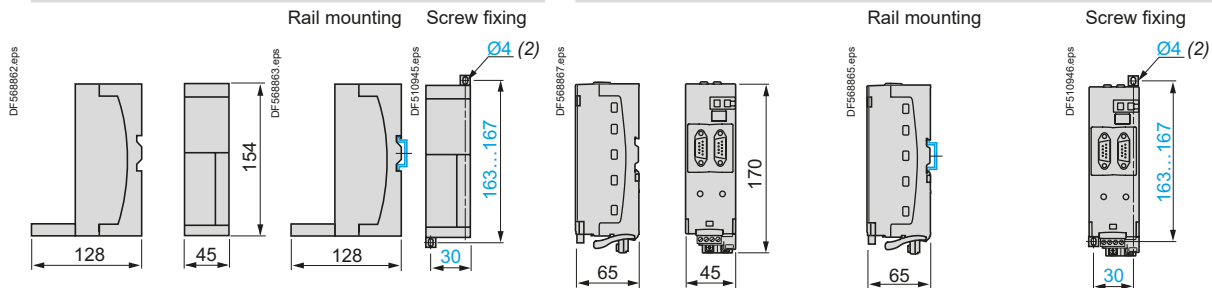

- (1) Depth with communication module.
- (2) Retractable fixing lugs.

References:
pages A4/20, A4/31, A4/32

12, 32, 38 A power bases with standard, advanced or multifunction control unit

LUB

Non-reversing

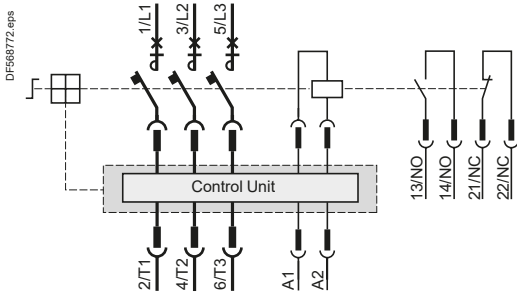

With control unit LUCC or LUCM

Connection of a single-phase motor

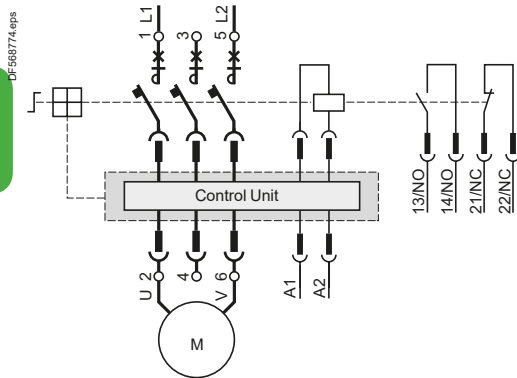

LU2B

Reversing

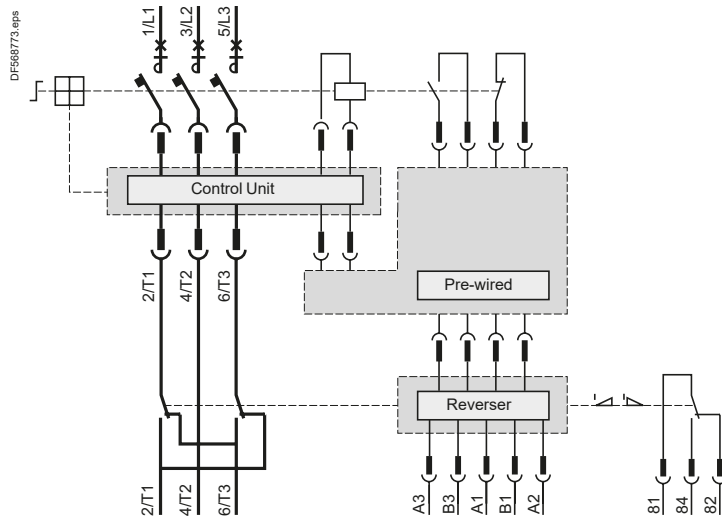

Control terminal block

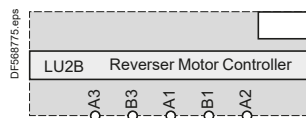

Reverser blocks

LU2M

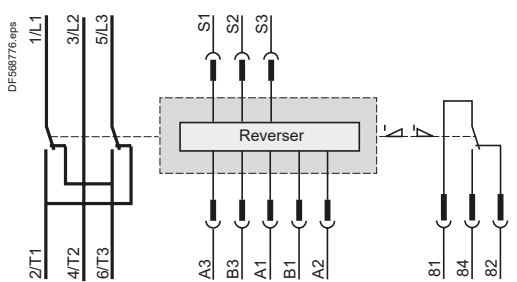

Control terminal block

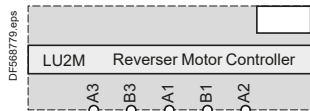

LU6M

Control terminal blocks

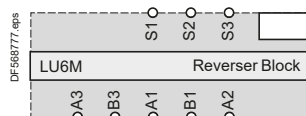

With pre-wired connector LU9MRC

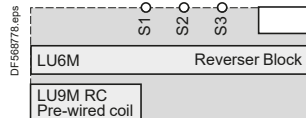

Basic scheme

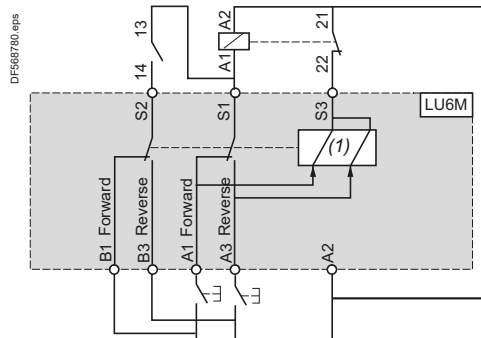

- S1 Start next stage
- S2 Electrical interlocking
- S3 Maintaining contact
- B1 Maintain forward running
- B3 Maintain reverse running
- A1 Pulse forward running
- A2 Common
- A3 Pulse reverse running
- (1) Electronically operated bistable electromagnet.

Add-on contact blocks

LUA1C11

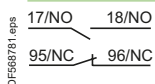

LUA1C20

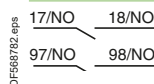

LUA8E20

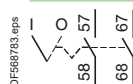

Add-on contact modules

LUFN20

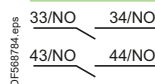

LUFN11

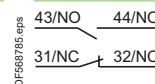

LUFN02

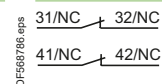

TeSys

TeSys U All-in-one motor starters - Terminal identifications

Schemes

Control units

Standard control units LUCA

Basic scheme

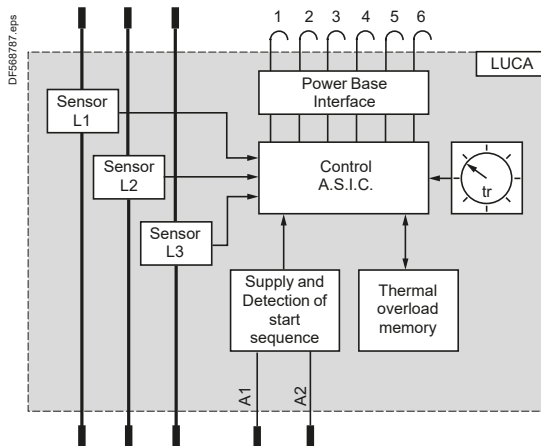

- 1 and 2 Trips
- 3 and 4 Electromagnet
- 5 Power base rating
- 6 N/C

Advanced control units LUCB, LUCC, LUCD

Basic schemehd

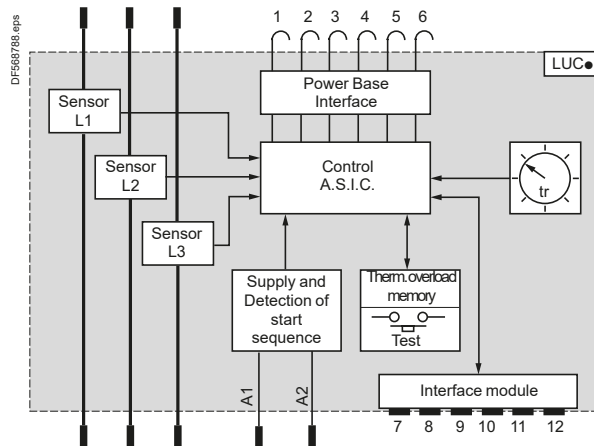

- 1 and 2 Trips
- 3 and 4 Electromagnet
- 5 Power base rating
- 6 N/C
- 7 Earth
- 8 Thermal status/Set
- 9 Reset mode/Reset
- 10 (Im/Ir)
- 11 Vc2
- 12 Vc1

Multifunction control units LUCM

Control terminal block

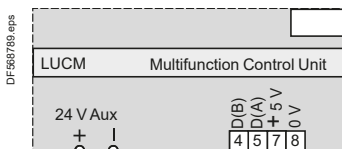

Basic scheme

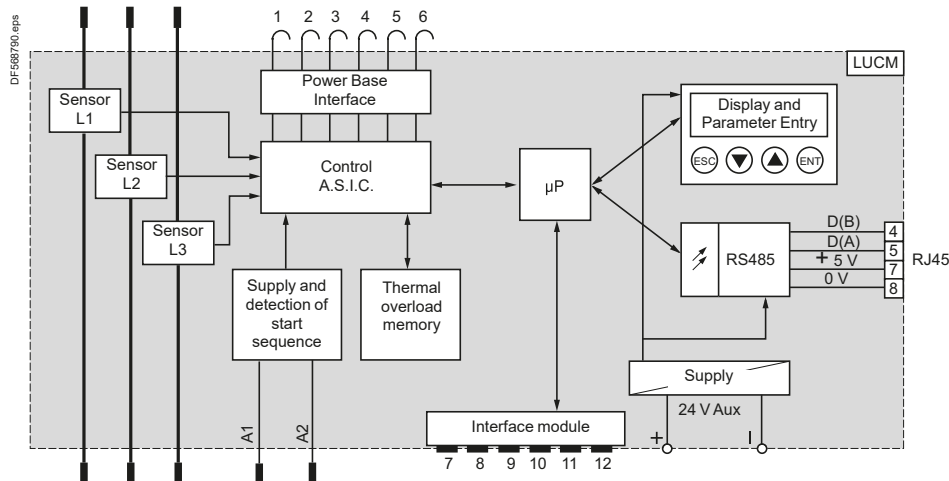

- 1 and 2 Trips
- 3 and 4 Electromagnet
- 5 Power base rating
- 6 N/C
- 7 Earth
- 8 N/C
- 9 Earth
- 10 (Im/Ir)
- 11 Rx/Tx
- 12 Vc1

References:
pages A4/11 and A4/12

Characteristics:
pages A4/45 to A4/47

Curves:
pages A4/54 to A4/56



TeSys

TeSys U All-in-one motor starters - Terminal identifications

Schemes

Function modules

Alarm LUFW10



Basic scheme

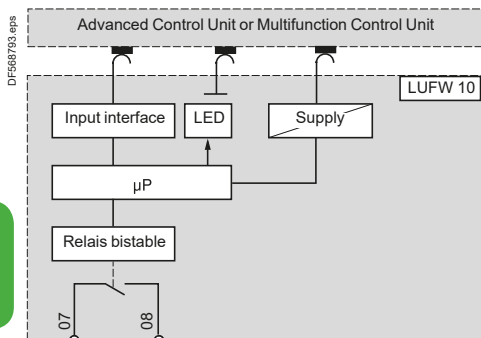

~ 250 V, 2 A
 ≍ 24 V, 2 A

Indication of motor load LUFV2

4-20 mA output

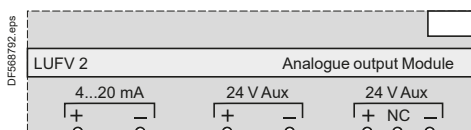

Basic scheme

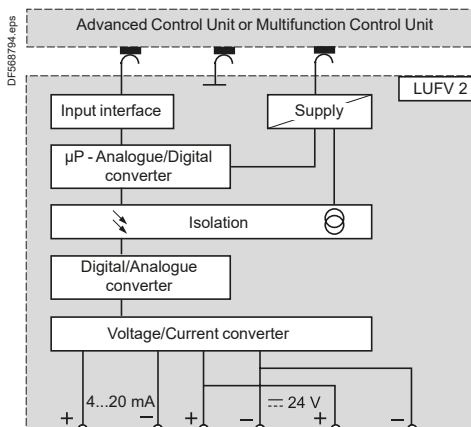

100 Ω < load < 500 Ω ≍ 30 V max and 40 mA min

Communication modules

Communication modules ASILUFC5 and ASILUFC51

Without pre-wired coil connection

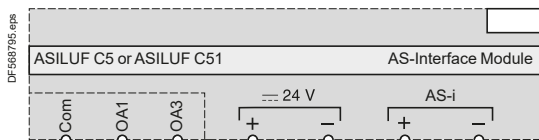

With pre-wired coil connection LU9BN11C

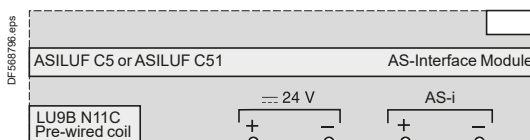

With pre-wired coil connection LU9MRC

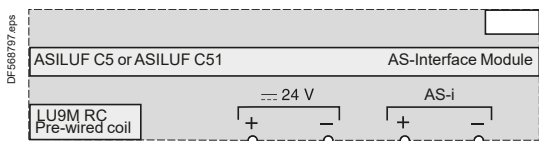

Basic scheme

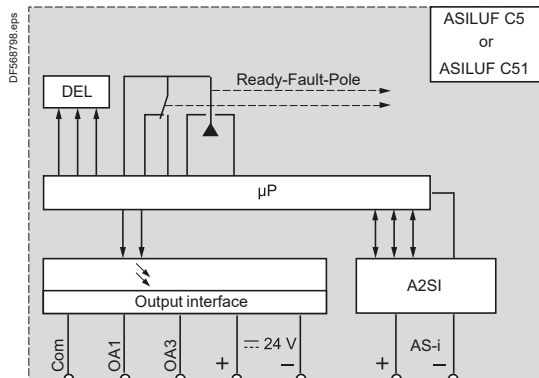

References:
 pages A4/13, A4/24

Characteristics:
 pages A4/48 to A4/53

Communication modules (continued)

With pre-wired coil connection LU9BN11C

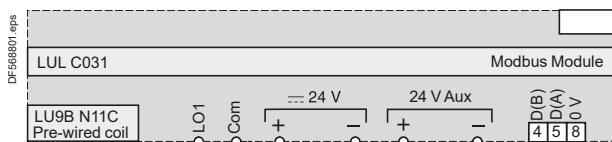

Modbus communication module LULC033

Without pre-wired coil connection

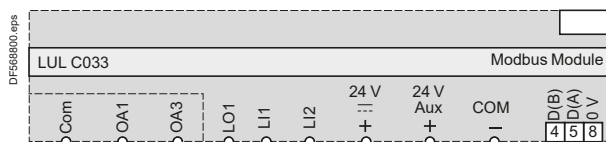

With pre-wired coil connection LU9MRC

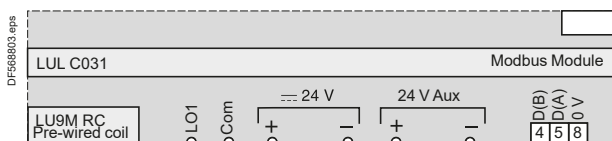

With pre-wired coil connection LU9BN11C

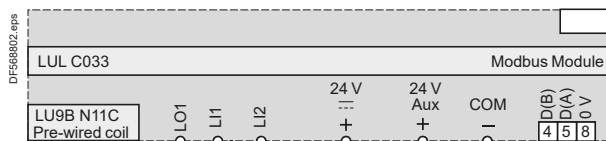

Basic scheme

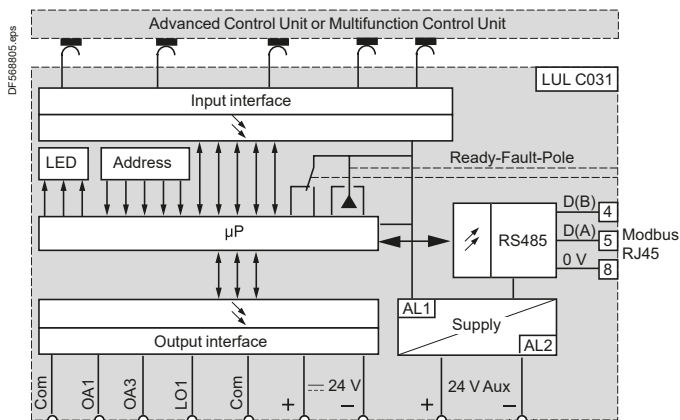

With pre-wired coil connection LU9MRC

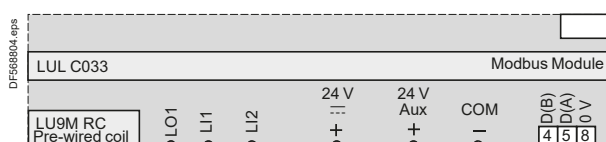

Basic scheme

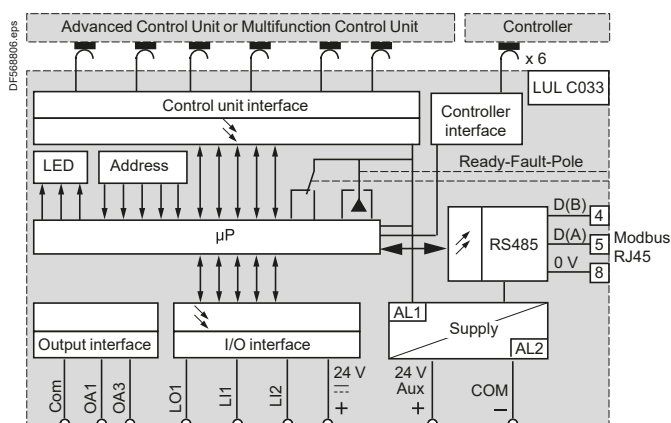

Communication modules (continued)

Profibus DP communication module LULC07

Without pre-wired coil connection

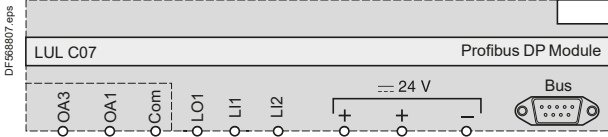

With pre-wired coil connection LU9BN11LC

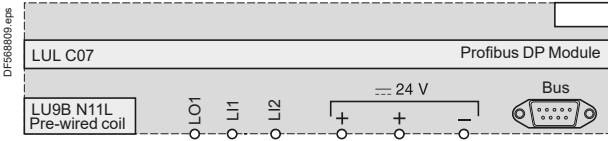

With pre-wired coil connection LU9MRC

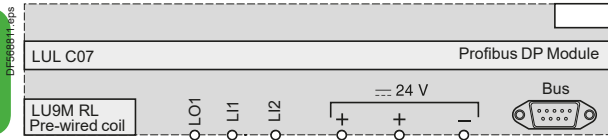

CANopen communication module LULC08

Without pre-wired coil connection

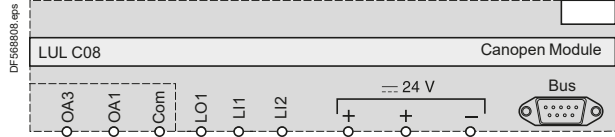

With pre-wired coil connection LU9BN11LC

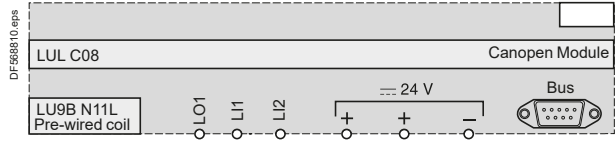

With pre-wired coil connection LU9MRC

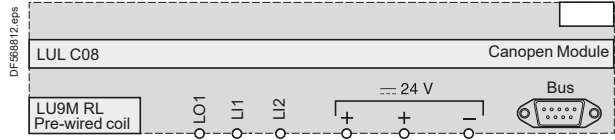

Basic scheme

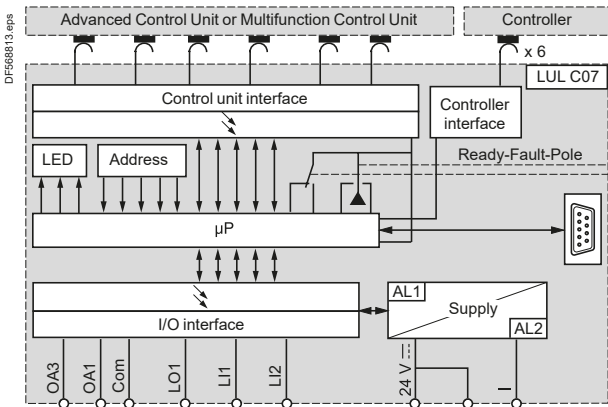

Basic scheme

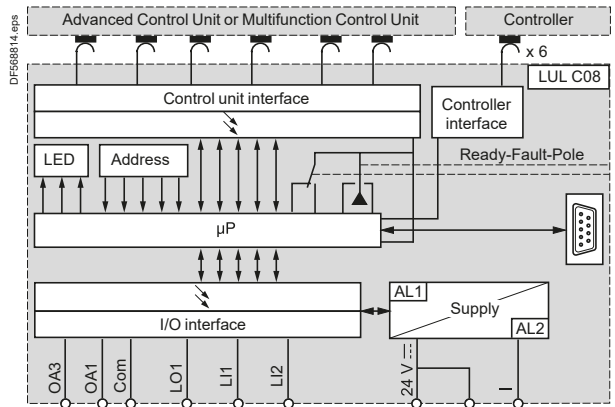

DeviceNet communication module LULC09

Without pre-wired coil connection

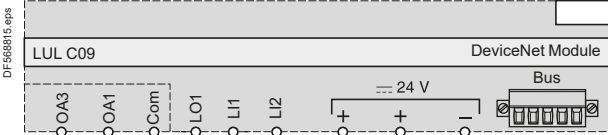

With pre-wired coil connection LU9BN11LC

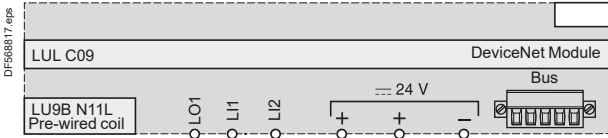

With pre-wired coil connection LU9M RL

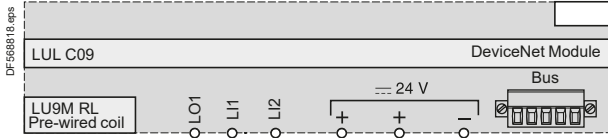

Basic scheme

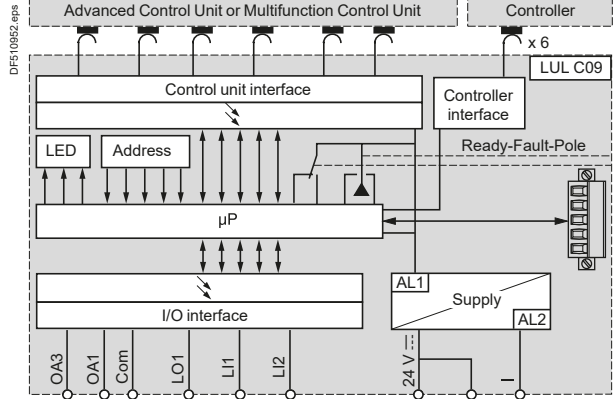

Communication modules (continued)

Advantys STB communication module LULC15

Without pre-wired coil connection

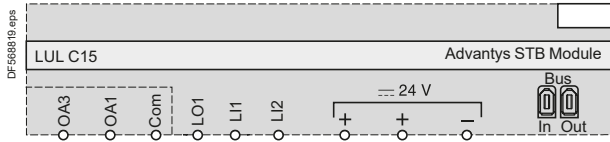

With pre-wired coil connection LU9BN11LC

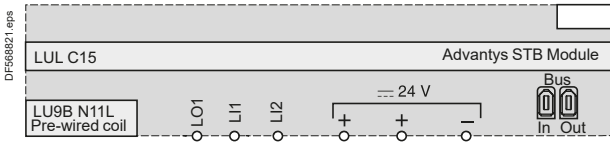

With pre-wired coil connection LU9MRC

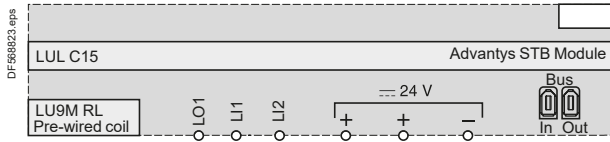

Basic scheme

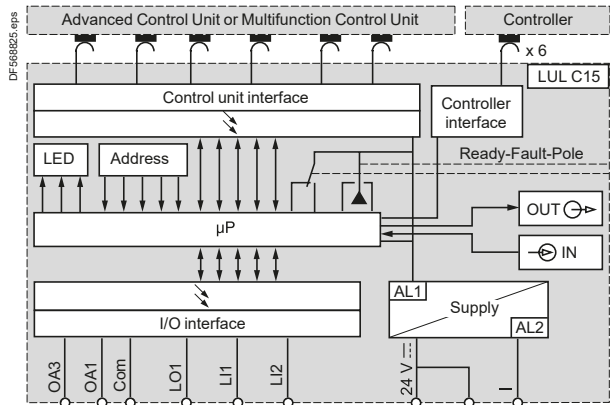

Parallel wiring modules

Without pre-wired coil connection



With pre-wired coil connection LU9BN11LC

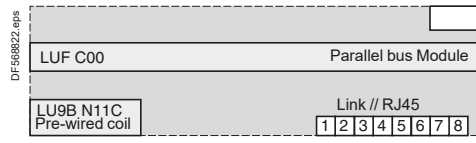

With pre-wired coil connection LU9MRC

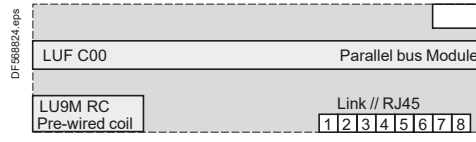

Basic scheme

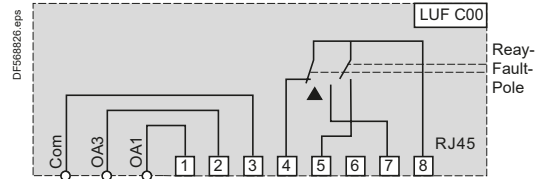

- 1 Forward running
- 2 Reverse running
- 3 Output common
- 4 Selector in position
- 5 Pole state
- 6 Reserved
- 7 Fault
- 8 Input common

Profibus DP power supply module LU9GC7

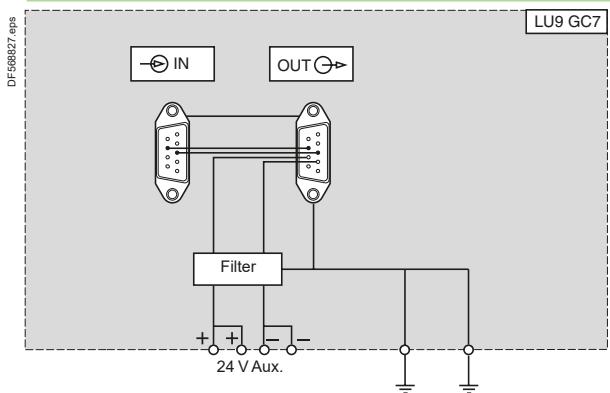

Communication modules (continued)

Wiring hub and splitter boxes

Modbus hub LU9GC3

Parallel wiring splitter box LU9G02

Parallel wiring splitter box LU9G03

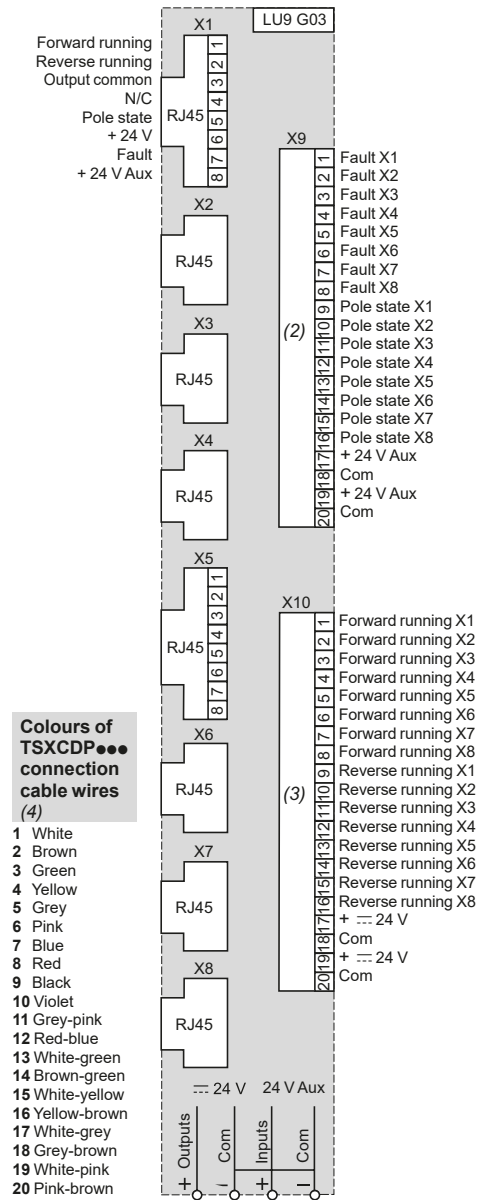
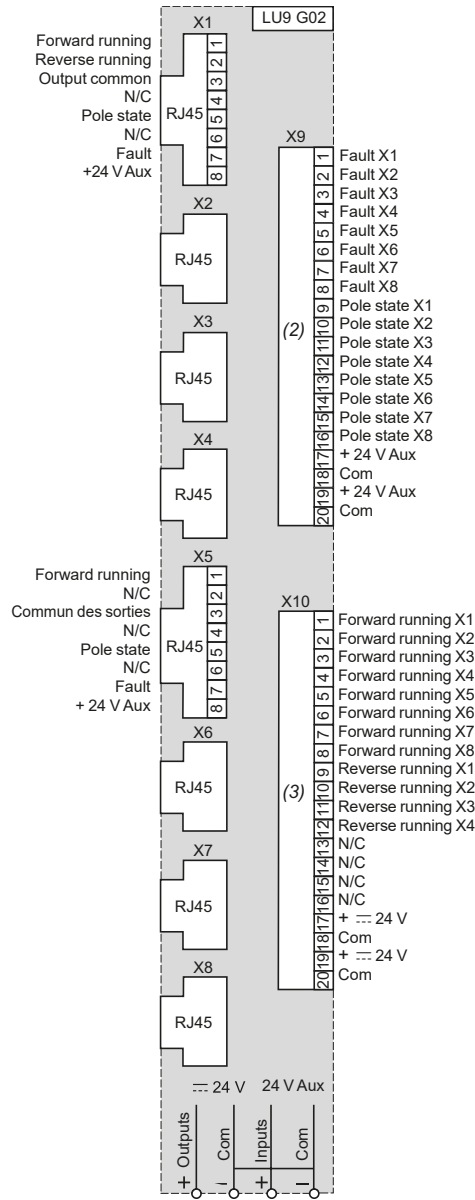
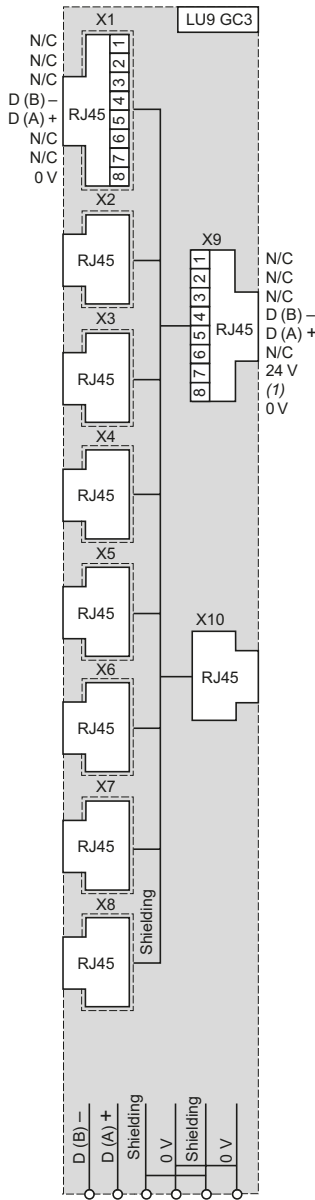

- Colours of TSXCDP... connection cable wires (4)**
- 1 White
 - 2 Brown
 - 3 Green
 - 4 Yellow
 - 5 Grey
 - 6 Pink
 - 7 Blue
 - 8 Red
 - 9 Black
 - 10 Violet
 - 11 Grey-pink
 - 12 Red-blue
 - 13 White-green
 - 14 Brown-green
 - 15 White-yellow
 - 16 Yellow-brown
 - 17 White-grey
 - 18 Grey-brown
 - 19 White-pink
 - 20 Pink-brown

(1) Not connected on connectors X1 to X8. Only present on RJ45 IN and OUT connectors.
 (2) 20-way HE10 input connector.
 (3) 20-way HE10 output connector.
 (4) Wire colours and corresponding HE10 connector pin numbers.

Gateways

LUF P1

LUF P7

LUF P9

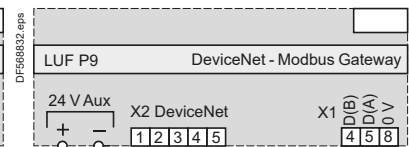
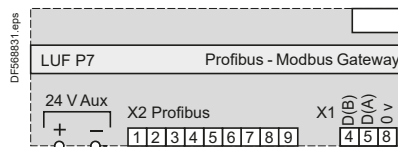
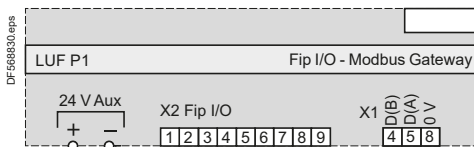

Non-reversing starter-controllers LUB

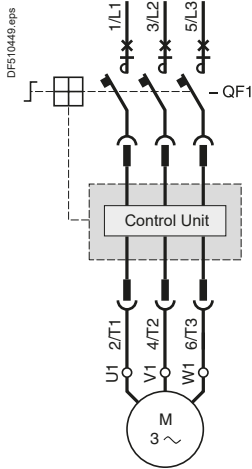

2-wire control via 2-position switch

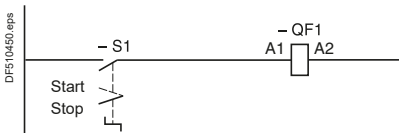

3-wire control, pulsed start with maintaining contact

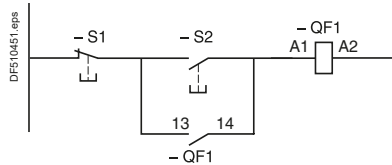

Connection of a motor load indicator module LUFV2

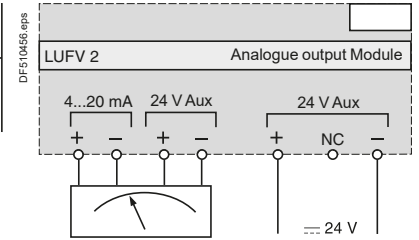

Connection of thermal overload fault signalling modules LUFDA10

Automatic reset

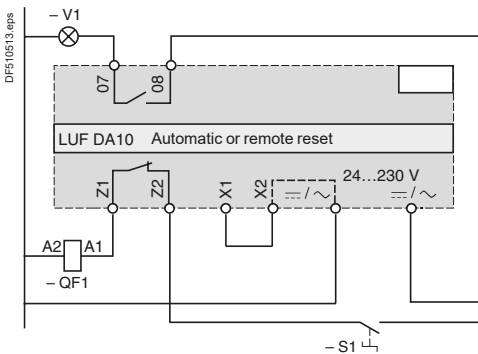

Remote reset

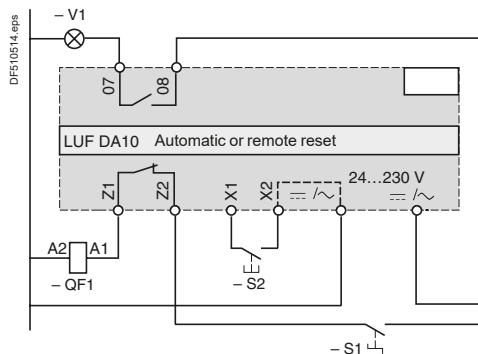

Control via Modbus communication module LULC033

Without pre-wired coil connection

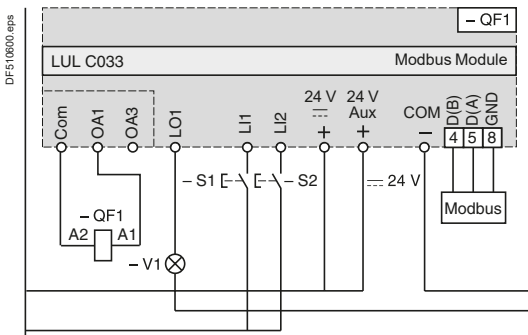

Non-reversing starter controllers LUB (continued)

Control by communication modules ASILUFC5 and ASILUFC51

Without pre-wired coil connection

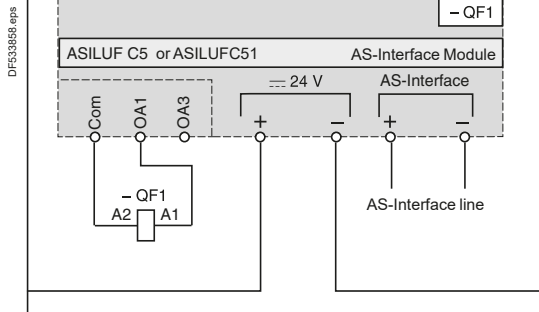

Without pre-wired coil connection With local control

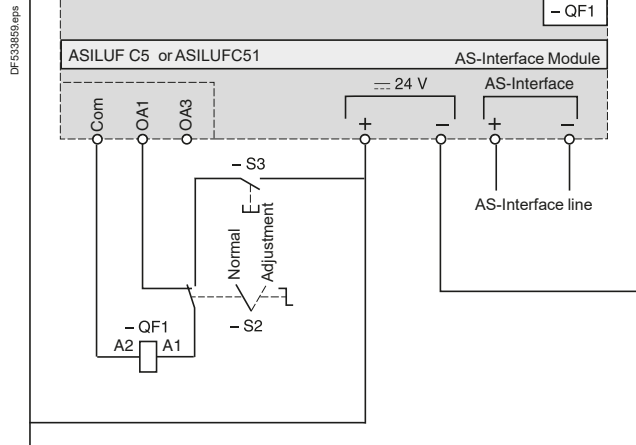

With pre-wired coil connection LU9BN11C

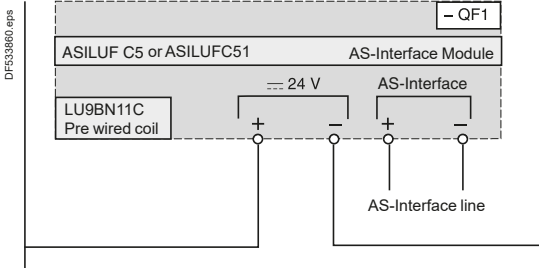

Without pre-wired coil connection With local control

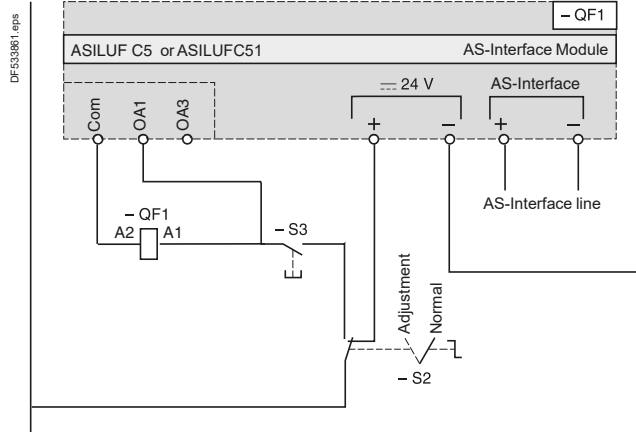

Without pre-wired coil connection With multifunction control unit LUCM

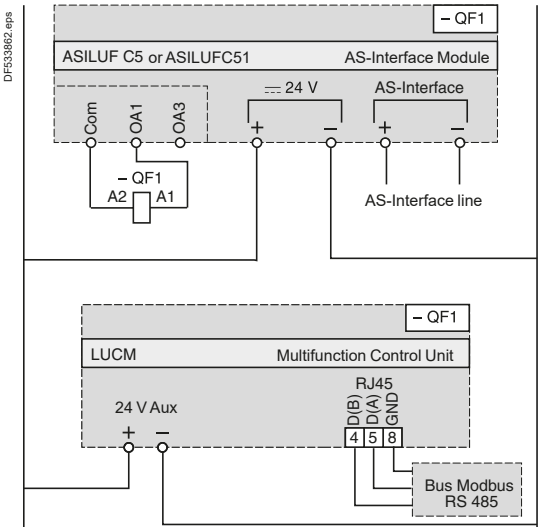

Standard or advanced power base

ON/OFF control (1 direction of rotation)

Push buttons wiring

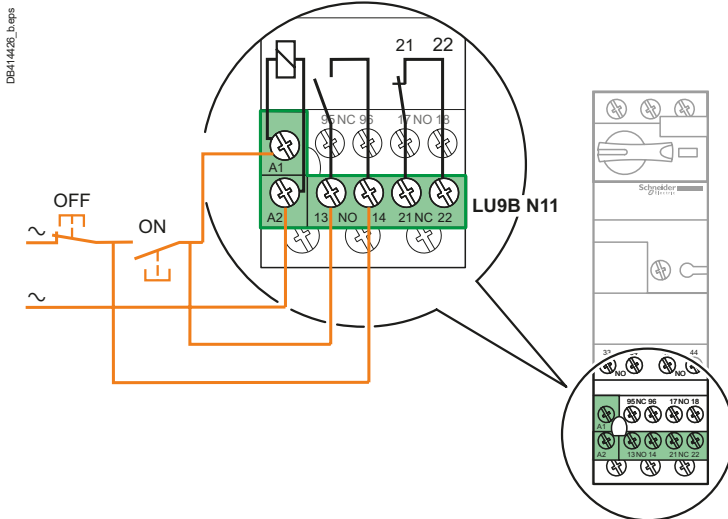

ON indication

"Motor RUN" indicator wiring

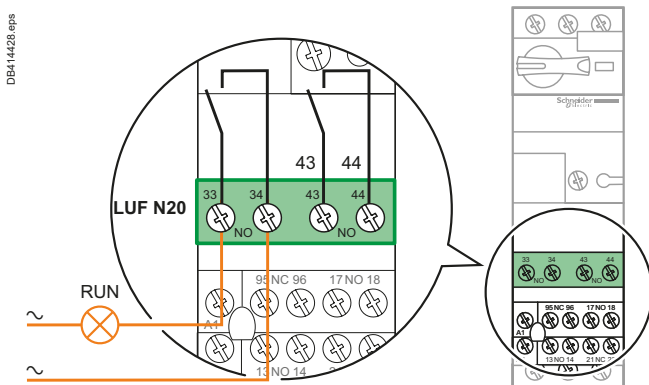

"Motor starter READY" indicator wiring

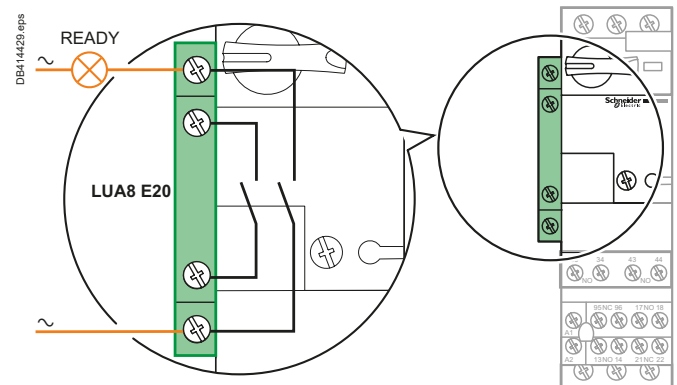

ALARM indication

Protection device status indicator wiring

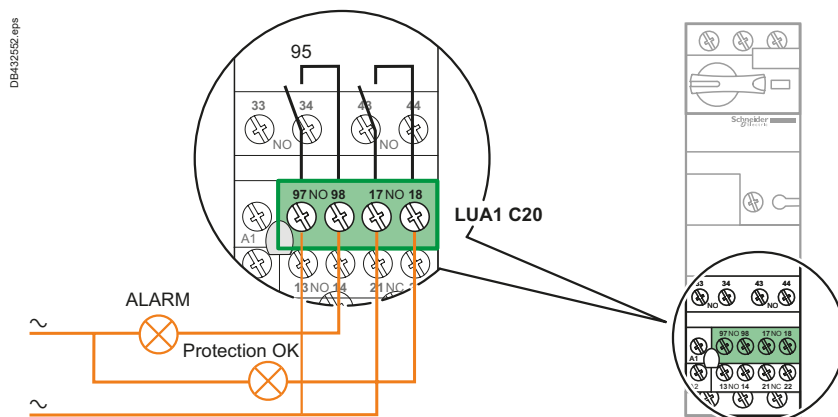

Reversing starter-controllers LUB

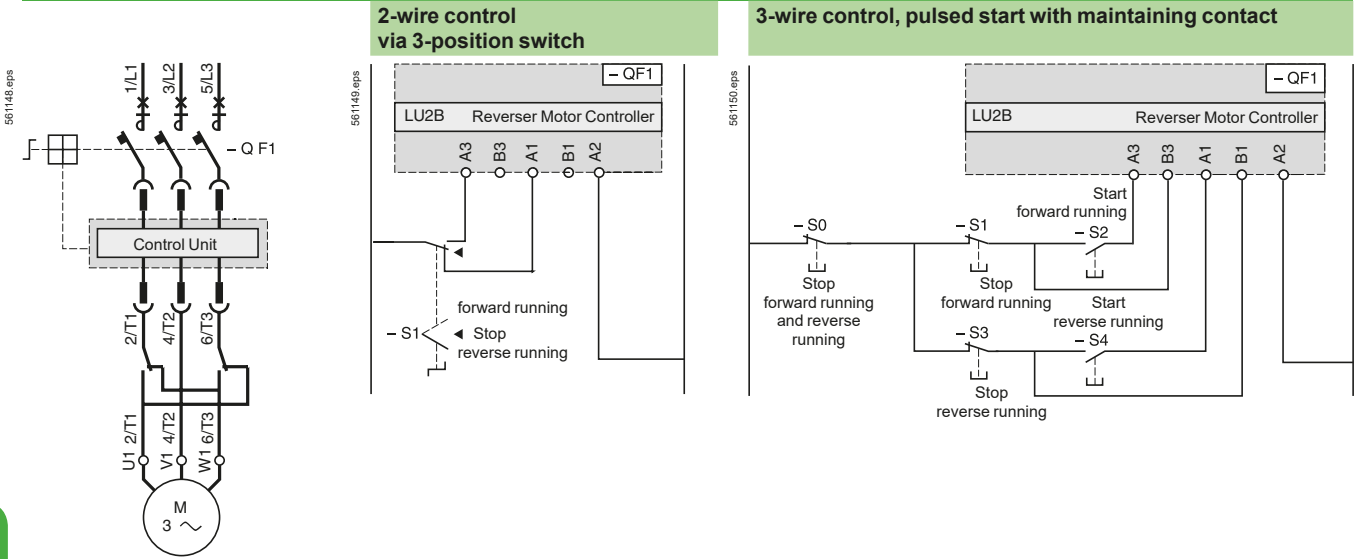

TeSys U

Control by communication modules ASILUFC5 and ASILUFC51

With pre-wired coil connection LU9MRC
With multifunction control unit LUCM

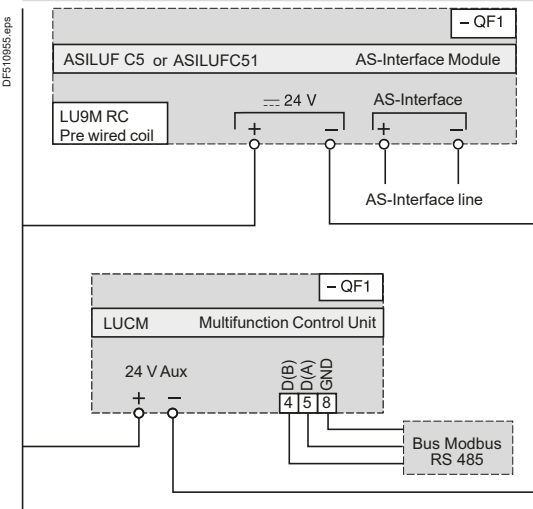

Ref.

3-wire control, pulsed start with maintaining contact and limit switches

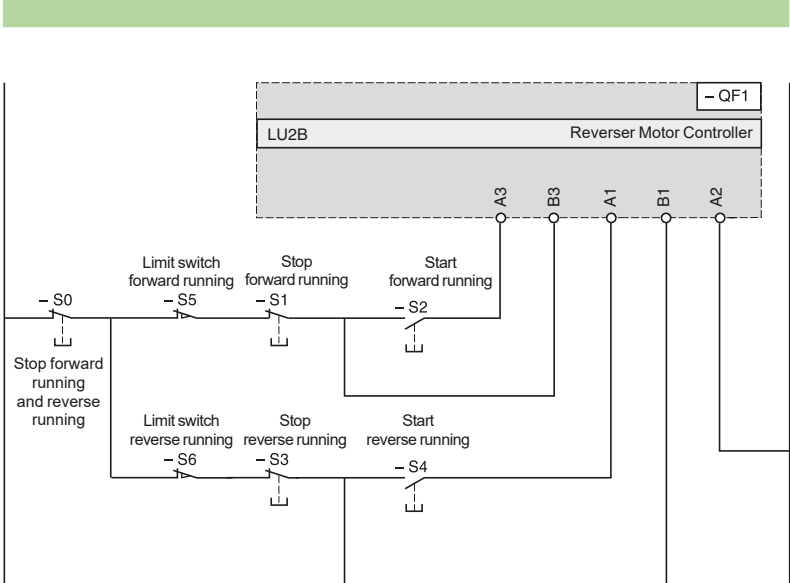

Control by communication modules ASILUFC5 and ASILUFC51

Without pre-wired coil connection
With running direction pilot lights and limit switches

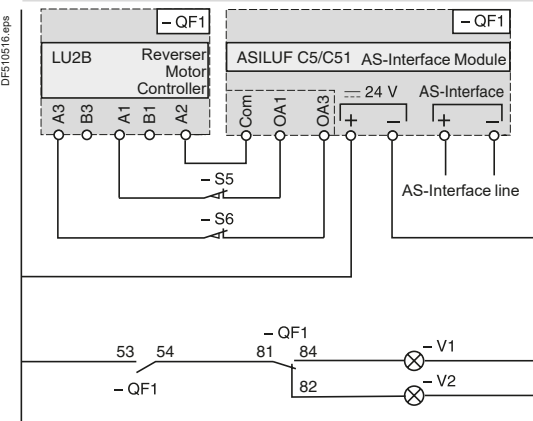

References:
pages A4/10 and A4/24

Reversing starter controllers LU2B (continued)

Control via Modbus communication module LULC033

Without pre-wired coil connection. With local control

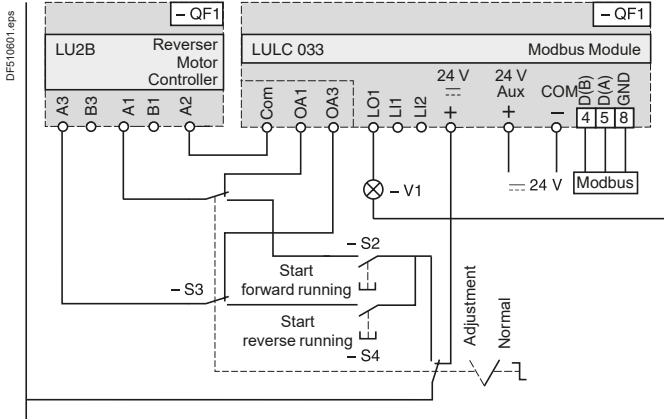

Reversing starter-controllers LUB + LU6M

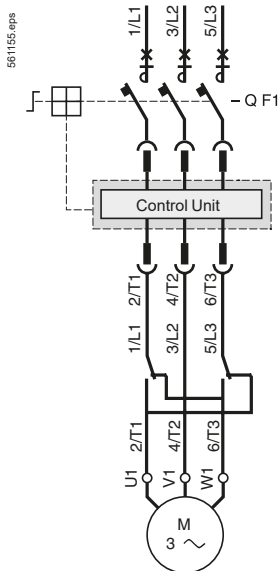

3-wire control, pulsed start with maintaining contact

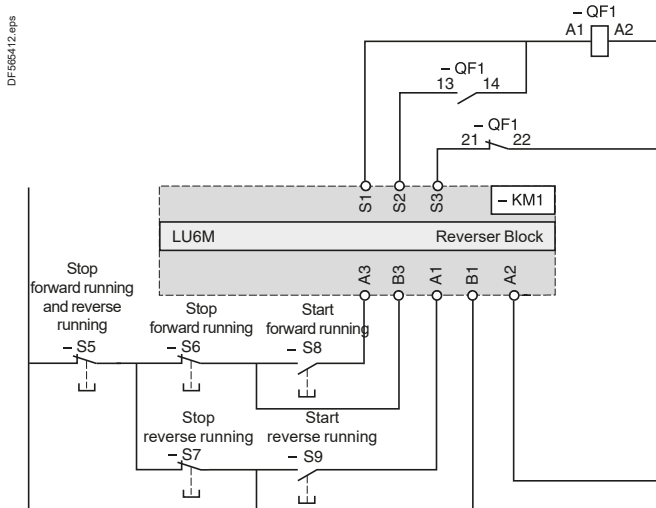

2-wire control via 3-position switch

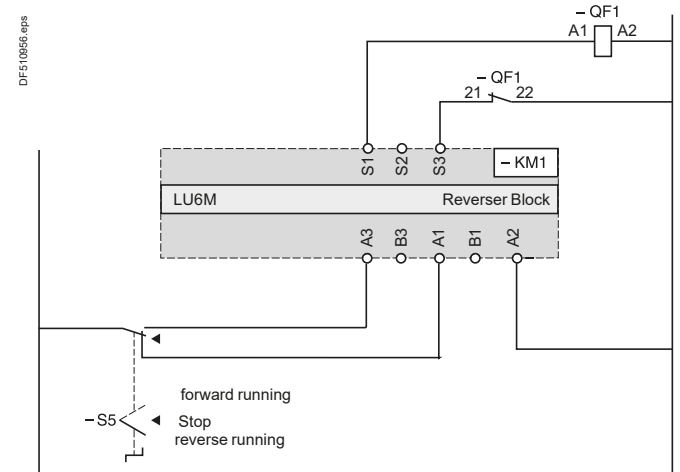

Power base with vertical mounting reverser block

FW/REV/OFF control (2 directions of rotation)

Push buttons wiring

FW/REV control

FW, REV indicators wiring

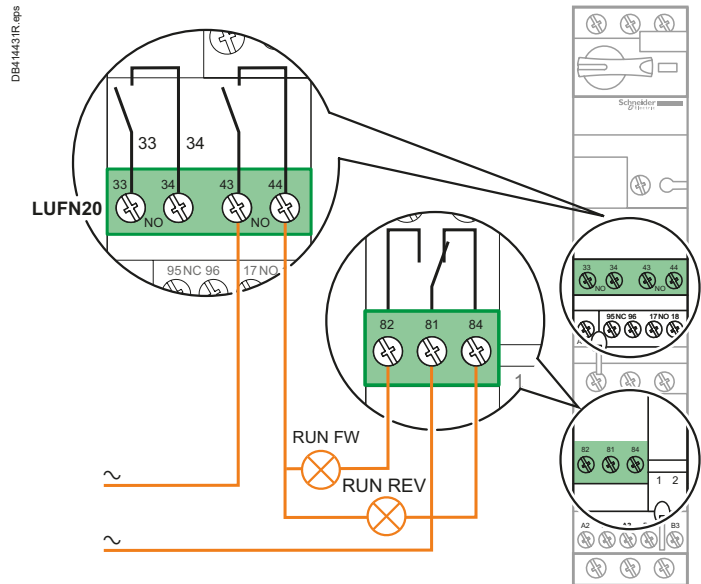
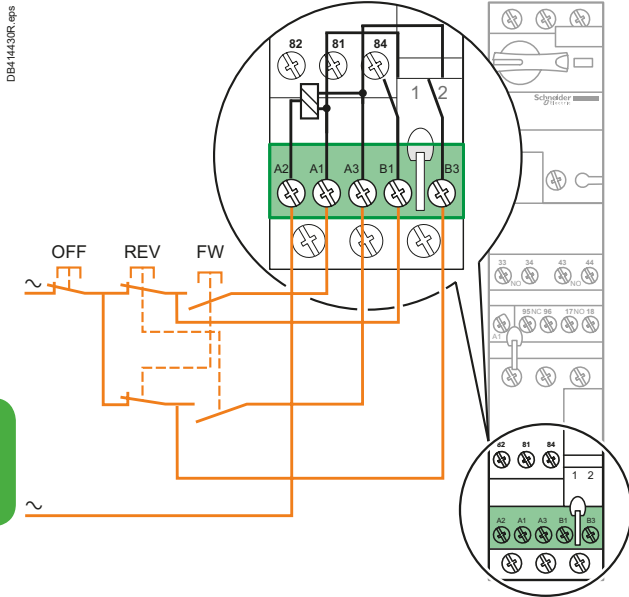

TeSys

Altistart U01 Soft starter

Characteristics

Environmental characteristics

Type of starter		ATSU01N2●●LT	
Conformity to standards		Altistart U01 electronic starters have been developed to conform to the strictest international standards and the recommendations relating to electrical industrial control devices (IEC, EN), in particular standard IEC/EN 60947-4-2.	
Electromagnetic compatibility EMC		CISPR 11 level B, IEC 60947-4-2, level B	
Conducted and radiated emissions		CISPR 11 level B, IEC 60947-4-2, level B	
Harmonics		IEC 1000-3-2, IEC 1000-3-4	
EMC immunity		EN 50082-2, EN 50082-1	
Electrostatic discharge		IEC 61000-4-2 level 3	
Immunity to radiated radio-electrical interference		IEC 61000-4-3 level 3	
Immunity to electrical transients		IEC 61000-4-4 level 4	
Voltage/current impulse		IEC 61000-4-5 level 3	
Conducted and radiated emissions		IEC 61000-4-6 level 3	
Immunity to conducted interference caused by radio-electrical fields		IEC 61000-4-11	
Damped oscillating waves		IEC 61000-4-12 level 3	
CE marking		The starters carry CE marking in accordance with the European low voltage directives IEC/EN 60947-4-2.	
Product certifications		UL, CSA, C-Tick and CCC	
Degree of protection		IP 20	
Degree of pollution		2 conforming to IEC/EN 60947-4-2	
Vibration resistance		1.5 mm peak to peak from 3 to 13 Hz, 1 gn from 13 to 150 Hz, conforming to IEC/EN 60068-2-6	
Shock resistance		15 gn for 11 ms conforming to IEC/EN 60068-2-27	
Relative humidity		5...95 % without condensation or dripping water conforming to IEC 60068-2-3	
Ambient temperature around the unit		Storage	°C -25...+70 conforming to IEC/EN 60947-4-2
		Operation	°C -10...+40 without derating, up to 50°C with current derating of 2 % per °C above 40°C
Maximum operating altitude		m 1000 without derating (above this, derate the current by 2.2 % per additional 100 m)	
Operating position			
Maximum permanent angle in relation to the normal vertical mounting position			

Electrical characteristics

Type of starter		ATSU01N2●●LT						
Category of use		Conforming to IEC 60947-4-2						
Rated operating voltage		3-phase ~ voltage						
		V	200 - 10 % to 480 + 10 %					
Frequency		Hz	50 - 5 % to 60 + 5 %					
Output voltage		Maximum 3-phase voltage equal to line supply voltage						
Control supply voltage		24 V ~, 100 mA ±10 %						
Rated operating current		A	6...32					
Adjustable starting time		s	1...10					
Adjustable deceleration time		s	1...10					
Starting torque		%	30... 80 % of DOL motor starting torque					
Type of starter	ATSU	01N206LT	01N209LT	01N212LT	01N222LT	01N232LT		
Control power supply consumption		24 V ~, 65 mA						
Power dissipated		24 V ~, 100 mA						
At full load at end of starting		W	1.5	1.5	1.5	2.5	2.5	
In transient state at 5 times the rated operating current		W	61.5	91.5	121.5	222.5	322.5	
Type of starter		ATSU01N206LT to ATSU01N222LT			ATSU01N232LT			
Use								
Starting time		s	1	5	10	1	5	10
Maximum number of cycles per hour			100	20	10	50	10	5

Electrical characteristics (continued)

Logic input power supply (electrically isolated between power and control) + 24 V, COM		24 V \pm 10 % Isolated Max. current 100 mA
Logic inputs LI1, LI2, BOOST Stop, run and boost on start-up functions		Logic inputs with impedance 27 k Ω ; 24 V power supply (U max 40 V) Max. current 8 mA State 0 if U < 5 V and I < 0.2 mA State 1 if U > 13 V and I > 0.5 mA
Logic output LO1 End of starting signal		Open collector logic output: External 24 V power supply (minimum 6 V, maximum 30 V) Max. current 200 mA
Relay output R1A R1C		Normally open (N/O) contact Minimum switching capacity: 10 mA for 6 V --- Maximum switching capacity on inductive load ($\cos \phi = 0.5$ and L/R = 20 ms): 2 A for 250 V \sim or 30 V --- (AC-15) Maximum operating voltage 440 V
LED signalling	Green LED Yellow LED	Starter powered up Nominal voltage reached

Connections (maximum connection capacity and tightening torque)

Power circuit			Connection to \varnothing 4 mm screw clamps	
Flexible wire without cable end	1 conductor	mm ²	1.5...10	8 AWG
	2 conductors	mm ²	1.5...6	10 AWG
Flexible wire with cable end	1 conductor	mm ²	1...6	10 AWG
	2 conductors	mm ²	1...6	10 AWG
Rigid wire	1 conductor	mm ²	1...10	8 AWG
	2 conductors	mm ²	1...6	10 AWG
Tightening torque		N.m	1.9...2.5	
Control circuit			Screw connector	
Flexible wire without cable end	1 conductor	mm ²	0.5...2.5	14 AWG
	2 conductors	mm ²	0.5...1.5	16 AWG
Flexible wire with cable end	1 conductor	mm ²	0.5...1.5	16 AWG
	2 conductors	mm ²	0.5...1.5	16 AWG
Rigid wire	1 conductor	mm ²	0.5...2.5	14 AWG
	2 conductors	mm ²	0.5...1	17 AWG
Tightening torque		N.m	0.5	

Torque characteristics (typical curves)

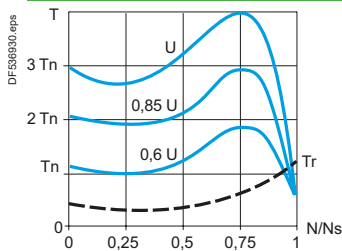

The diagram opposite shows the torque/speed characteristic of a cage motor in relation to the supply voltage. The torque varies in line with the square of the voltage at a fixed frequency. The gradual increase in the voltage prevents the instantaneous current peak on power-up.

TeSys

Altistart U01 Soft starter

Dimensions

TeSys U combination (non-reversing power base) and ATSU01N206LT to ATSU01N212LT

Mounting on \perp (35 mm) rail with VW3G4104 connector

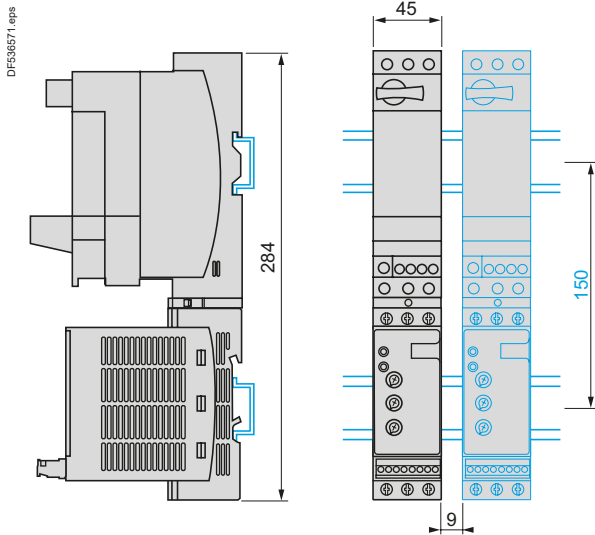

TeSys U combination (non-reversing or reversing power base) and ATSU01N206LT to ATSU01N212LT

Side by side mounting

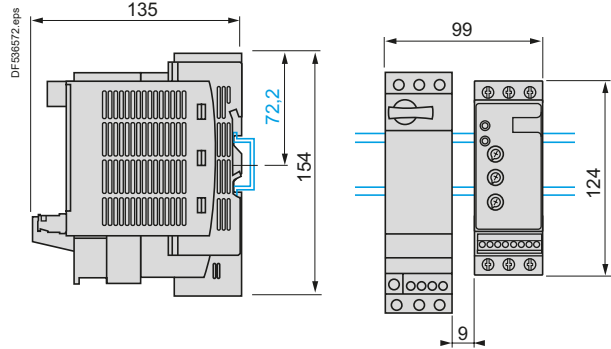

TeSys U combination (non-reversing power base) and ATSU01N222LT to ATSU01N232LT

Mounting on \perp (35 mm) rail with VW3G4104 connector

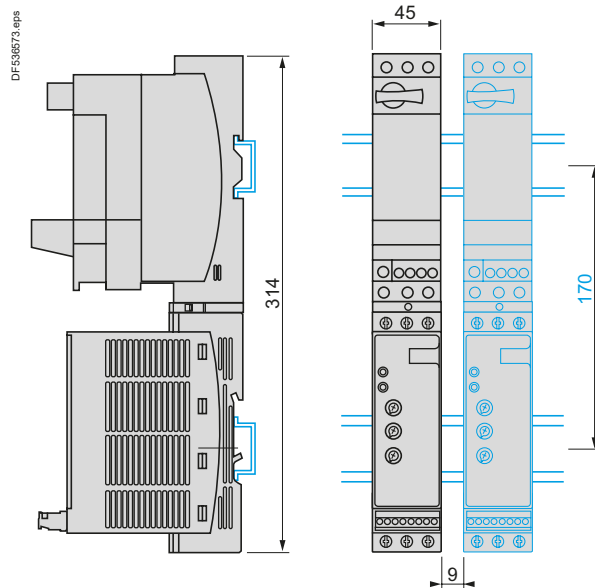

TeSys U combination (non-reversing or reversing power base) and ATSU01N222LT to ATSU01N232LT

Side by side mounting

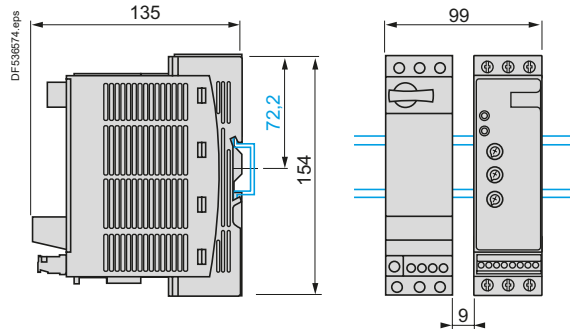

VW3G4104 connector

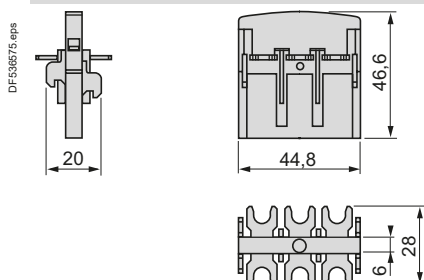

ATSU01N2●●LT soft start/soft stop units

Power wiring

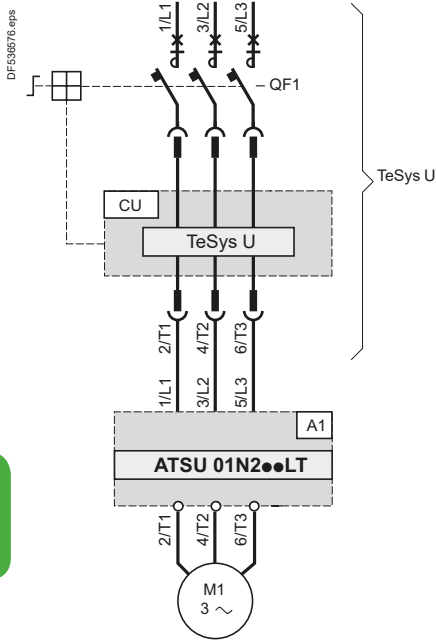

Power wiring with reversing unit

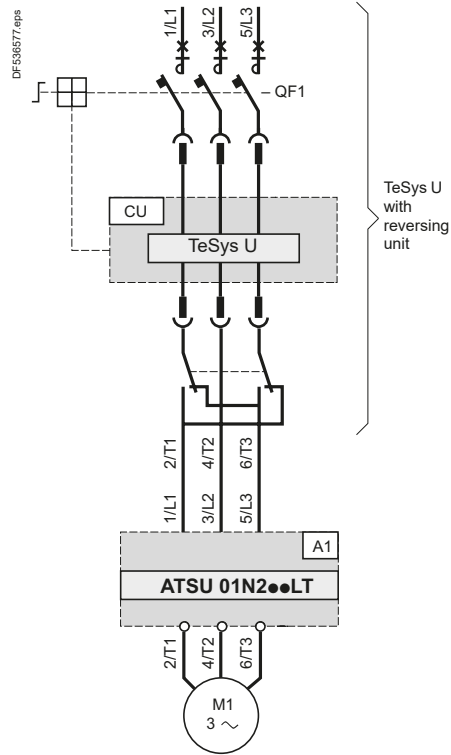

Compatible components

Code	Description
A1	Soft start/soft stop unit
QF1	TeSys U controller-starter
CU	TeSys U control unit

TeSys U

Ref.



ATSU01N2●●LT soft start/soft stop units (continued)

Automatic 2-wire control

Without deceleration

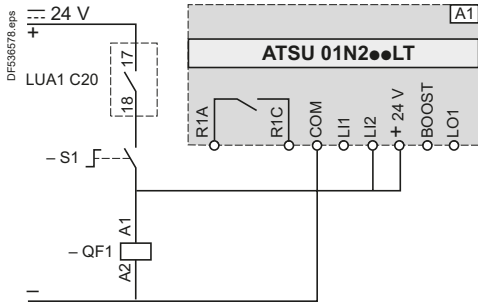

With and without deceleration

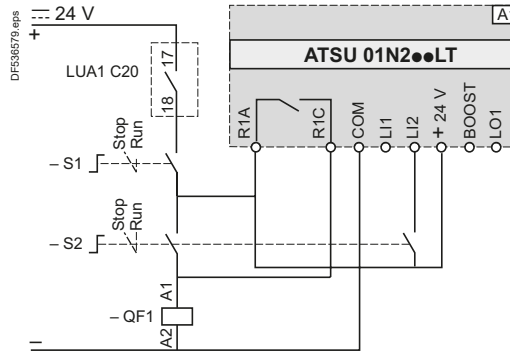

Functional diagrams

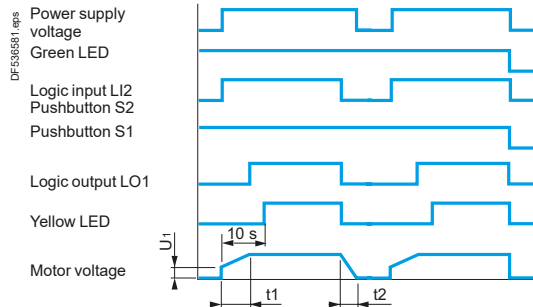
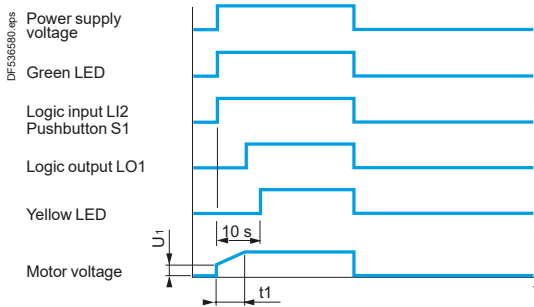

Automatic 3-wire control

Without deceleration

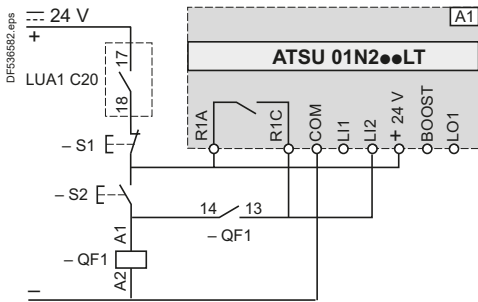

With deceleration

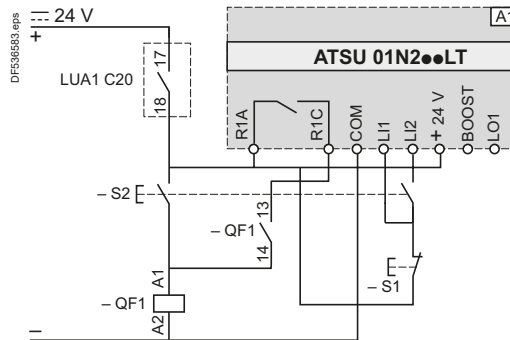

Functional diagrams

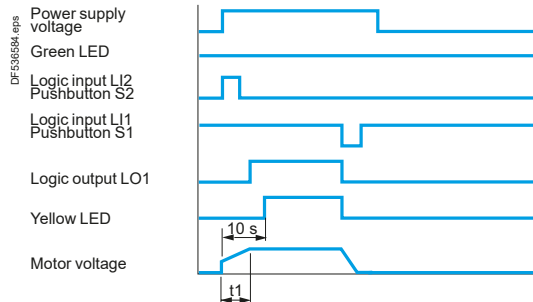
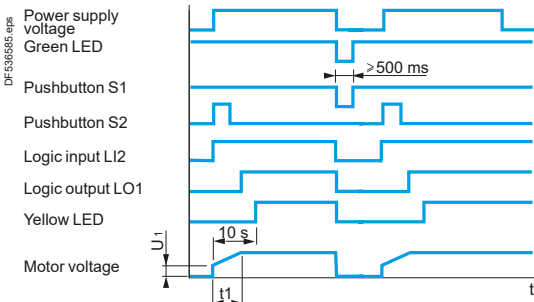

A1: Soft start/soft stop unit
 S1, S2: XB4B or XB5B pushbuttons
 QF1: TeSys U controller-starter
 t1: Acceleration time can be controlled by a potentiometer
 t2: Deceleration time can be controlled by a potentiometer
 U_s: Starting time can be controlled by a potentiometer

ATSU01N2●●LT soft start/soft stop units (continued)

Automatic 3-wire control, with reversing unit

Without deceleration

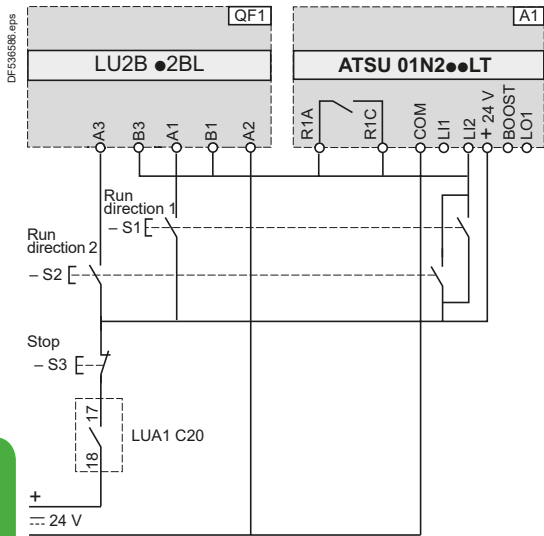

With deceleration

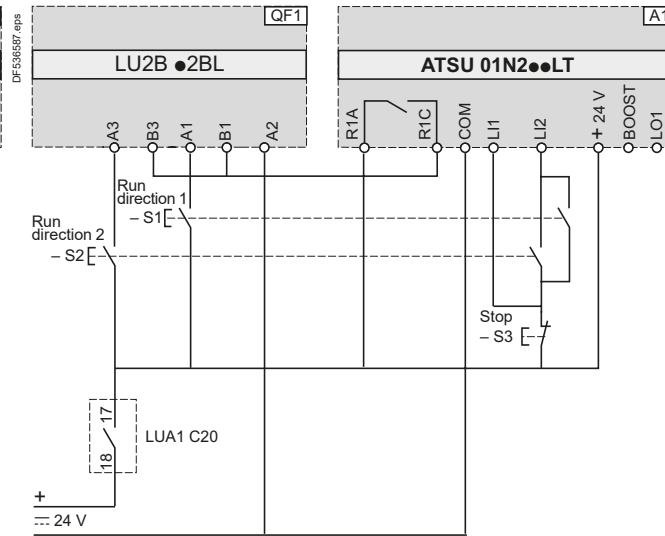

TeSys U

Ref.

QF1: TeSys U controller-starter with reversing unit
 A1: Soft start/soft stop unit
 S1, S2, S3: XB4B or XB5B pushbuttons
 S3: minimum depression time 500 ms

QF1: TeSys U controller-starter with reversing unit
 A1: Soft start/soft stop unit
 S1, S2, S3: XB4B or XB5B pushbuttons

Boost on starting and end of starting signal

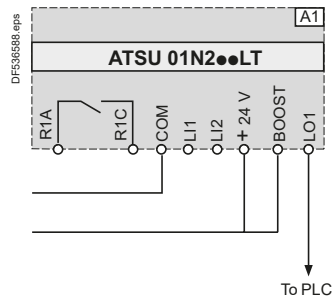

A1: Soft start/soft stop unit

ATSU01N2●●LT soft start/soft stop units (continued)

Automatic control with Modbus communication module, with and without deceleration

Without reversing unit

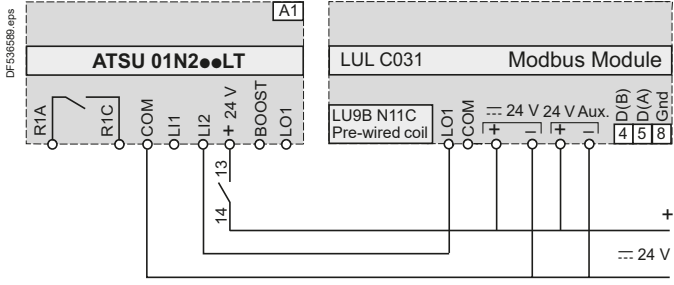

With reversing unit

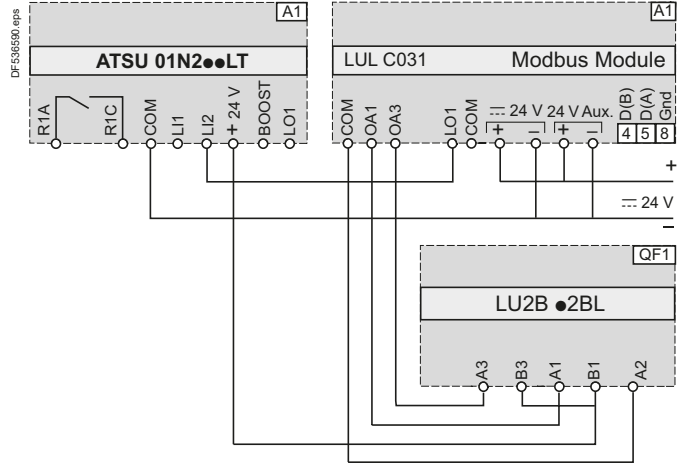

Function	Register	Bit	Value
Powering down TeSys U and ATSU			
-	704	0	0
Automatic control without deceleration			
Run	700	0	1
Stop	704	0	0
Automatic control with deceleration			
Run	700	0	1
Soft stop	700	0	0

Function	Register	Bit	Value
Powering up TeSys U and ATSU			
Forward	704	0	1
Reverse	704	1	1
Powering down TeSys U and ATSU			
Forward	704	0	0
Reverse	704	1	0
Automatic control without deceleration			
Run	700	0	1
Stop forward	704	0	0
Stop reverse	704	1	0
Automatic control with deceleration (forward or reverse)			
Run	700	0	1
Soft stop	700	0	0

A1: Soft start/soft stop unit

A1: Soft start/soft stop unit

QF1: TeSys U controller-starter with reversing unit

Automatic control with AS-Interface communication module, without deceleration

Without reversing unit

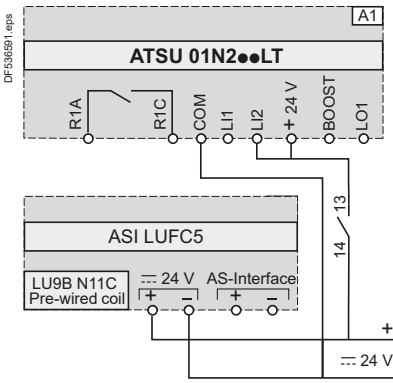

With reversing unit

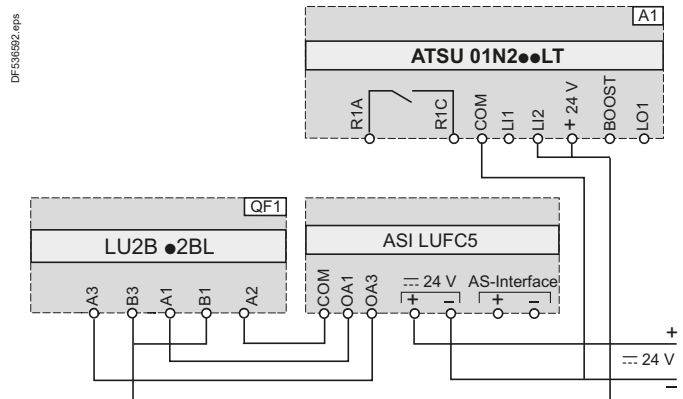

Function	Bit	Value
Power-up and automatic control without deceleration		
Run	D0	1
Stop	D0	0

Function	Bit	Value
Power-up and automatic control without deceleration		
Run forward	D0	1
Stop	D0	0
Run reverse	D1	1
Stop	D1	0

A1: Soft start/soft stop unit

A1: Soft start/soft stop unit

QF1: TeSys U controller-starter with reversing unit

